

INSTALLATION - SAFETY - MAINTENANCE

MANUAL

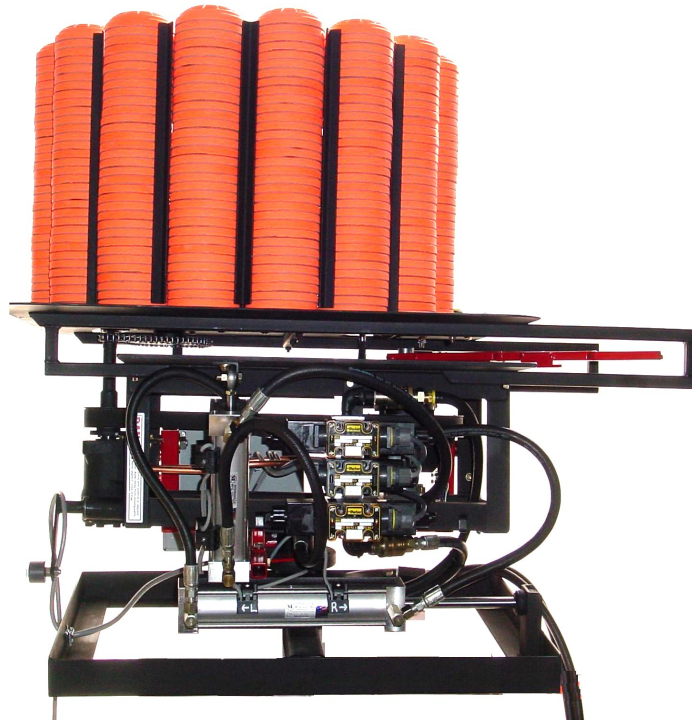

Pat-Trap[®]

Singles to Doubles In Seconds

Serial #: _____

Date: _____



WARNING

This Manual disclose details of a patented apparatus or device for throwing clay targets. The apparatus is clearly disclosed and claimed on our **U.S. Patent No. 5249563 and 6176229**. It is unlawful under United States Patent Law to practice, i.e. to make, use or sell a patented invention without the express permission of the owner/inventor thereof. Permission is expressly granted, **only to use**, the patented apparatus. The unauthorized making, using or selling of the patented apparatus constitutes patent infringement. It is the intent of the owner/inventor to prosecute infringers of the Patent to the full extent of the all applicable laws.



Table of Contents

Pat-Trap® Safety 1

Trap House Specifications 2

Installation of Pat-Trap machine and Hydraulic Pump..... 4

Serial # Location 5

Pat-Trap Machine Weight and Dimensions..... 5

Removal/Replacement of Turret 6

Mounting the Power Control Box..... 6

Connecting the Trap to the Power Source 7

How the Pat-Trap® works 8

Pat-Trap Switch Identification 10

Turning the Pat-Trap® On & Off 11

Loading the Pat-Trap® 11

Pat-Trap® Singles Height 13

Pat-Trap® Doubles Height..... 15

Adjustment for Pat-Trap® Doubles..... 16

Pat-Trap® Wobble Settings 17

Change over to Wobble Setting 18

Setting a Target Distance/Speed 19

Setting Minimum Target Distance..... 20

Adjustment Height of Targets..... 22

Angle Adjustments 23

Position of the Roller Plates 25



Table of Contents Cont.

Target Brush Maintenance.....	28
Cold Weather Adjustment, Temperature Release Time Stopping the Throw Arm on the Brake.....	29
Adjusting Release Time – Correction of Cycling Problem	30
Assembly and Maintenance of the Throw Arm Brake	32
Removal of Throw Arm.....	33
Disconnecting the Uni-Band (Main Spring) from the Clutch.....	34
Installation of the Throw Arm.....	34
Maintenance of the Cocking Pin.....	36
Installation of the “XXX”Doubles Finger	37
Replacement/Removal of Main shaft Clutch Assembly	39
Changing a Pair of Uni-Bands on a Main Shaft Clutch System	43
Assembly/Installation of the Uni-Band (Main Spring) to the Main Shaft Clutch.....	45
Replacement of the Elevator Extension Spring	48
Replacement of the Elevator Compression Spring.....	49
Throw Arm Shaft Bearing Maintenance	50
Hydraulic Valve Identification – Standard Trap	51
Hydraulic Valve Identification- Wobble Trap	52
Soft Shift Valve Wiring Guide (Oscillation/Wobble)	53
Single Solenoid Valve (Throw Arm/Turret) Wiring Guide.....	54
Replacement of a Hydraulic Valve.....	55
Wiring Guide for Field Angle Limit Switches (#11 & #12)	56



Table of Contents Cont.

Replace a Field Angle Limit Switch 57

Wobble Wiring Guide for Up and Down Limit Switches (#11A & #12A) .. 58

Replacement of Oscillation Cylinder 60

Replacement of Wobble Cylinder 62

General Maintenance Appendix I

Procedure to Flush Hydraulic Oil Appendix II

Timing of the Pinion.....Appendix III

Assembly of the Pinion and Sprocket.....Appendix IV

Pat-Trap Wiring Diagram & Wobble Wiring DiagramAppendix V

Drying Out a Pat-Trap after a flood.....Appendix VI

Trouble Shooting.....Appendix VII



The PAT-TRAP[®]

NEVER STAND IN FRONT OF A TRAP MACHINE. THE TRAP MACHINE MUST BE TURNED OFF AND THE SPRING RELEASED BEFORE ENTERING THE TRAP HOUSE. NEVER ATTEMPT TO MAKE ANY ADJUSTMENT WHILE THE THROW ARM IS COCKED.

DO NOT TOUCH! -- ASK FOR HELP

NEVER ATTEMPT TO LOAD THE TRAP WHEN IT IS COCKED. ALWAYS RELEASE THE TARGET FROM THE TRAP MACHINE.

NEVER ADVANCE THE THROW ARM BY HAND WHEN THE ON/OFF/RELEASE SWITCH IS IN THE ON POSITION. THIS MAY DAMAGE THE MACHINE.

The target throw arm extends 4" beyond the throw plate. Keep away from moving parts. Never stand in front of the trap machine.

When the machine is turned ON the throw arm will travel forward to the cocked position through the danger zone.

When the throw arm is fired, the arm will travel through the indicated danger area zone.

The throw arm can be fired by pushing the pullcord button. It can also be fired by hand; by pushing the arm forward off the brake when the machine is either On or Off.

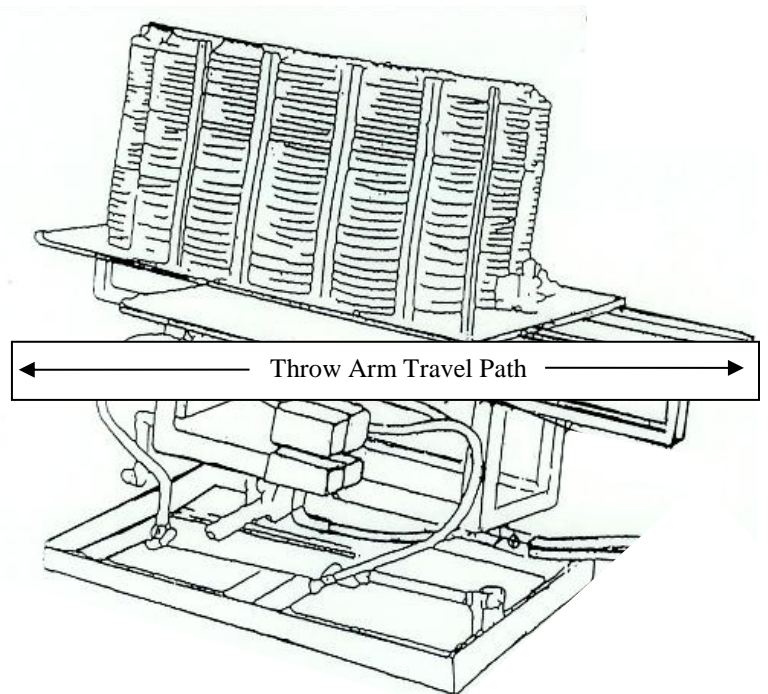



Top-Down Suggested Plan View of Trap House

1. Water proof all sides below 4" grade.
2. Open front trap houses are preferred if grade allows it.
3. All Walls and Roof are shown as 4" thickness.
4. Reinforce concrete per local building codes.
5. Install drainage as required.
6. Trap House Door should be weather proof and can be locked.
7. Trap House length in not less than 7'6" or more than 9'6" per ATA.
8. Trap House width is not less than 7'6" or more than 9'6" per ATA.

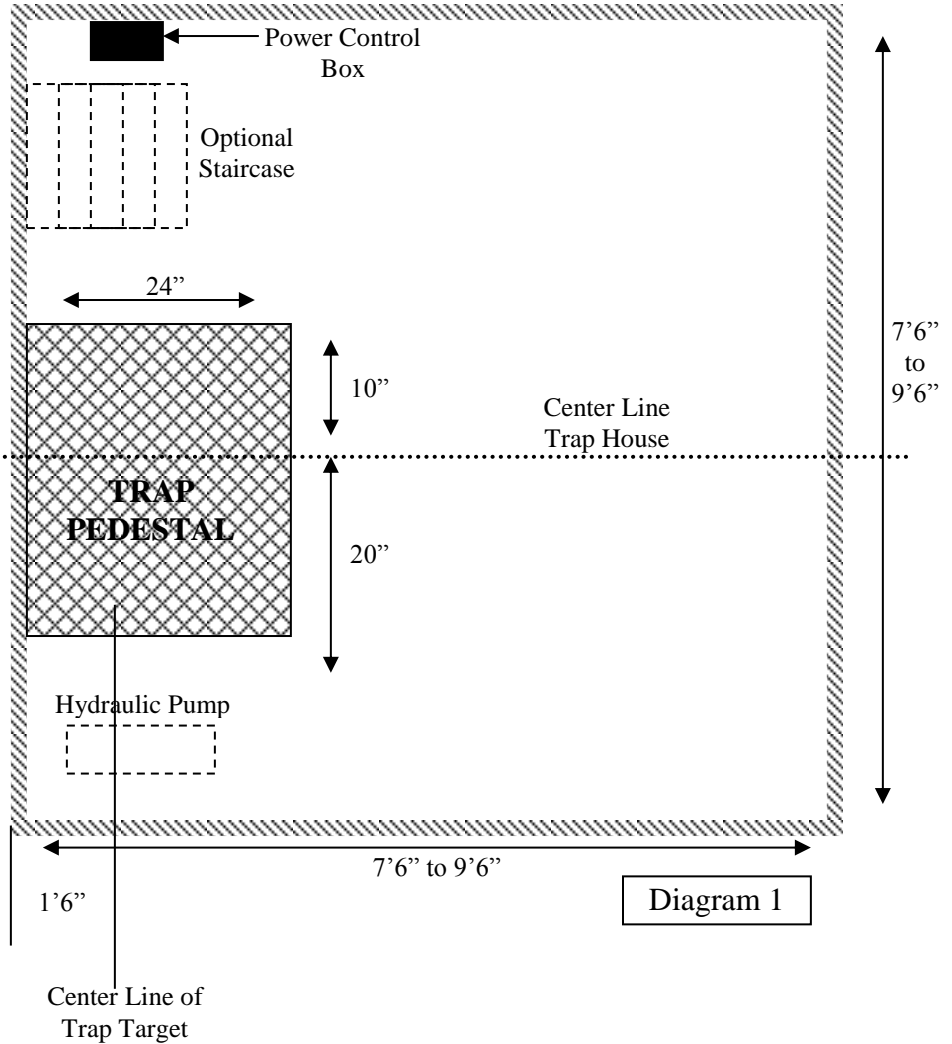



Side View (Cross Section) of Trap House

1. Paint Roof and Rear Wall Green.
2. Water Proof All Sides Below Grade.
3. Open Front Trap Houses are preferred if grade permits. Trap house opening is a minimum of 26" to a maximum of 43". Wall minimum of 0" from top of pedestal to a maximum of 16" from top of pedestal.
4. All Walls and Roof are shown as 4" Thick.
5. Reinforce Concrete Per Local Building Codes.
6. Install Drainage as Required.
7. Trap House Door Should be Weather Proof and Capable of Being Locked.
8. Trap House Length is Not Less Than 7'6" or More Than 9'6"
9. Trap House Height is 2'2" Minimum and 3'0" Maximum from Shooting Station #3.

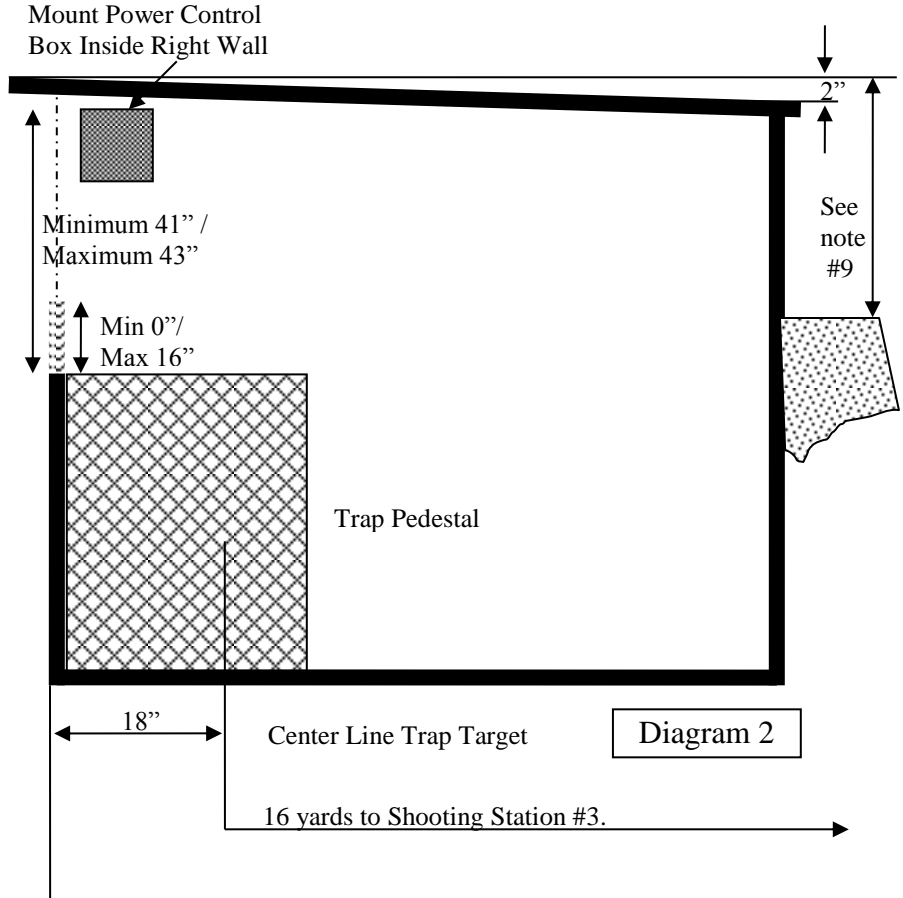

For Complete Rules: See Amateur Trapshooting Association Official Rules Section XIII Standards for Trap Houses, Targets, Target Settings, Guns and Ammunition.



Installation of the Trap Machine and Hydraulic Pump

1. Place the trap machine in the trap house with the front of the machine as close as possible to the front wall. The platform which the trap sits on *must be level*. See Diagram 2. If necessary, the turret may be removed from the machine to place the trap into the house. Please refer to page 6 for instructions.
2. The trap is to be set *off center* of the trap house. See Diagram 1.

Measure and mark the center of the trap house. The front of the base is marked with a notch at 10” in from the left – facing the front of the machine. Set the machine so that this notch is now at the center of the trap house. The base of the trap machine should be set at 41” minimum from the ceiling; however, a setting of approximately 43” is best for loading targets.

3. Holes are provided in the corners of the base to screw down/secure your machine.
4. Place the pump on a raised platform (ie: a cinder block and you may place a foam or rubber pad underneath to reduce vibration is desired) on the left side of the trap house. See Diagram 1. If flooding is a problem in your area then mount the pump on a platform that is above the water line. The pump reservoir is filled at the factory with **5W-20** oil.



Hydraulic Pump System

Diagram 3

5. If not already connected, connect the quick release fittings from the pump hydraulic hoses to the hoses at the rear of the trap machine; slide back the outer sleeve of the female fitting while pushing on to the male fitting. Allow the female sleeve to slide forward to lock. Gently tug on the connections to check that they are securely fastened.



PAT-TRAP® SERIAL NUMBER LOCATION

A fully crated Pat-Trap is 420 #.
 Machine and pump weighs 350 #.
 Turret weigh 50 #.
 Pump weight 50 #.
 Pat-Trap machine w/o pump and
 turret weight 250 #.

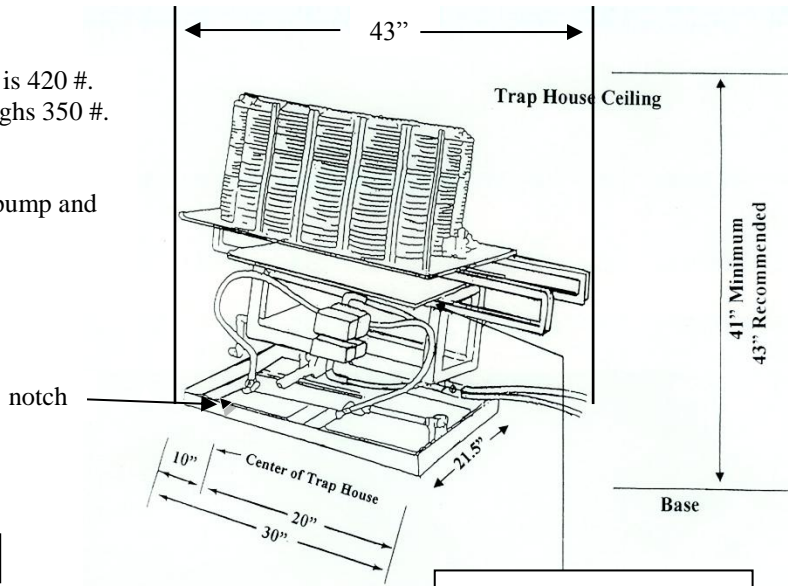

Measurements of the Pat-Trap machine

From the bottom of the base to the top of the King Pin 24"

From the bottom of the base to the top of the turret 34 3/4"

Trap cog top max – 39 1/2"
 Trap cog bottom min – 37"

Wobble base to throw plate (up/down angles) min 17 3/4"

Wobble base to throw plate (up/down angles) max 24 1/2"

Wobble max – 39 1/2"
 Wobble Min – 34 3/4"

Diagram 4

The Serial Number is stamped on the edge of the 1/4" steel plate.

Base Dimensions of PAT-TRAP®



Serial Number is stamped here.
 Example: "G4190"
 Also located on pump.

Diagram 5

PAT-TRAP® Serial Number Location

Serial Number Location: The Serial Number is stamped on the front left edge (shooting stand 1 Side) of the 1/4" thick steel "Throw Plate".



REMOVAL/REPLACEMENT OF THE TURRET

WARNING: To prevent damage to your machine the turret must be replaced the same way as it was removed.

1. Observe how the cogs are meshed with the cam followers: i.e., the pair of cam followers has to mesh within the cogs located beneath the turret.
2. To remove the turret, have two people, one on each side of the trap machine, lift straight up (no tools are required). Both people must lift up evenly to prevent the turret from binding on the kingpin. Replace the turret in the same way that it was removed.

MOUNTING THE POWER CONTROL BOX

1. Mount the power control box just inside the trap house on the right wall near the ceiling of the trap house (See Diagrams 1). This should be the side of the trap where personnel enter/exit the trap house. The power control box should be easily accessible so that it can be operated by placing your hand around the corner of the wall and not exposing your body to the front of the trap machine. The power control box will also be accessible to trap personnel when setting the machine for Doubles. Proper location of the control box is important to insure safety.

NEVER STAND IN FRONT OF A TRAP MACHINE. THE TRAP MACHINE MUST BE TURNED OFF AND THE SPRING RELEASED BEFORE ENTERING THE TRAP HOUSE. NEVER ATTEMPT TO MAKE ANY ADJUSTMENT WHILE THE THROW ARM IS COCKED.

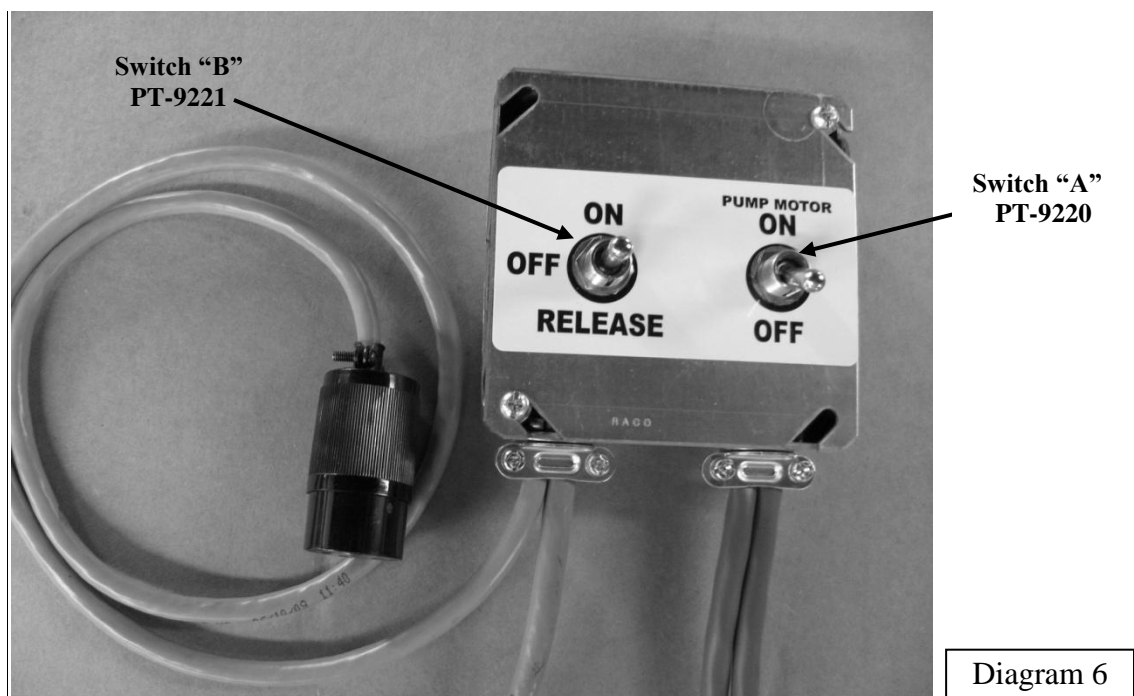

Close Up of Pat-Trap® Power Control Box (PT SP80)



CONNECTING THE TRAP TO THE POWER SOURCE

1. Check the power control box to confirm that the *motor* and the *on/off/release* switches are in the **OFF** position. When both toggle switches are snapped downward they are in the OFF position (Diagram 6).
2. Connect the pump to the power control box by plugging the pump motor outlet coming from the power control box.
3. The trap machine uses 110 volt AC power. Connect the trap machine to the power source using the male plug from the power control box.
4. Connect the pullcord to the female connector from the power control box. The pullcord must have a male twist lock connector (Winchester type pullcord).



Diagram 7

Pull Cord Complete
P/N9320
Or
Voice Release
Connection

Male and Female
Power Cord
P/N SP82

Male to 110AC Power

Female



HOW THE PAT-TRAP® AUTOMATIC DOUBLES MACHINE WORKS

Turn the switch marked “Pump Motor” to the On Position, and let the pump warm up.

Turn the switch marked “On/Off/Release” to the On Position to energize the PAT-TRAP®. The elevator rises to receive a target while the throw arm and turret advance. When a target is loaded, the elevator goes down and the throw arm advances the target until the Activator comes to the #2 and #3 switch bracket (See Diagram 9). The throw arm is now at the brake (in the cocked position - Diagram 8) and the target is set.



Diagram 8

Throw Arm on Throw Arm Brake

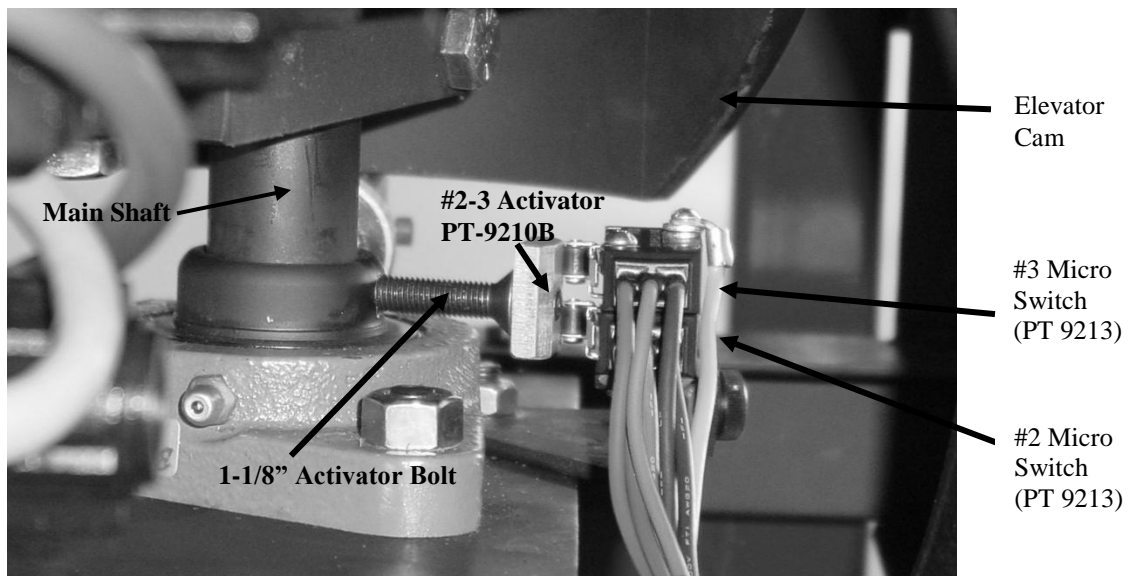

Diagram 9

Pat-Trap® #2 & #3 Switch Bracket in “Cocked Position”



When the trap release switch is activated, Switch #1 overrides Switch #2 which then advances the throw arm off the throw arm brake causing the machine to fire. (See Diagram 11)

When the activator leaves Switches #2 and #3, the #2 switch closes and begins a new cycle of loading a target. The #3 switch also closes, which starts the oscillation interrupter for a pre-determined length of time. (Diagram 10)

** The machine oscillates to the left until Switch #12 (Left Angle Limit Reed Switch - N.O.) comes to the magnet, activating Relay #2, causing the machine to change direction to the right (Diagram 10).

Switch #11 holds the Relay engaged until Switch #11 (Right Angle Limit Reed Switch - N.O.) comes to the magnet, breaking the circuit which then disengages Relay #2 causing the machine to oscillate back to the left. (Diagram 79)



Pat-Trap® #12 & #11 Limit Reed Switches on Oscillation Cylinder

Diagram 10

The switching sequence is the same for the wobble machine.

Diagram 11

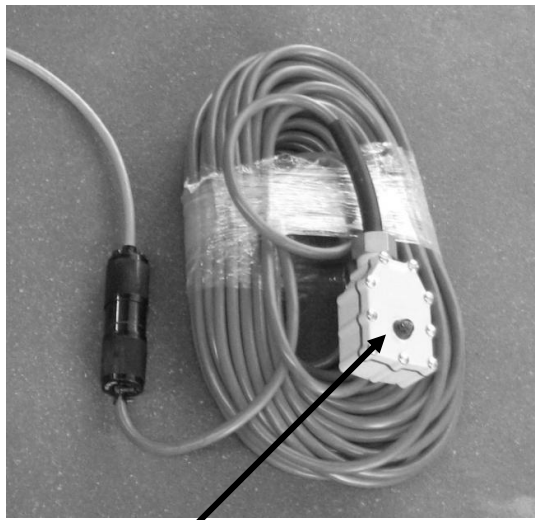

#1 Switch Trap Release Switch

Wobble Cylinder PT-9013M

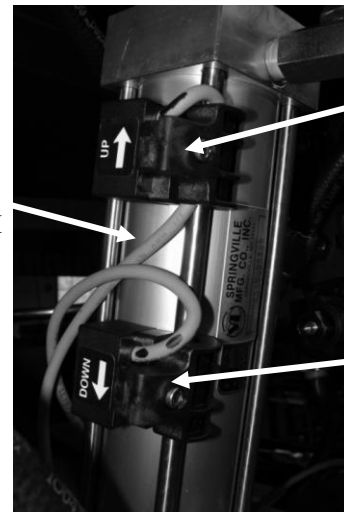

"UP" Limit Reed Switch #11A (N.O.) PT-9223

Diagram 12

"DOWN" Limit Reed Switch #12A (N.O.) PT-9222

#11A & #12A Limit Reed Switches on Wobble Cylinder



PAT-TRAP® SWITCH IDENTIFICATION.

- Switch #A PAT-TRAP® Pump Motor Switch (See Diagram 6)
- Switch #B PAT-TRAP® On/Off/Release Switch (See Diagram 6)
- Switch #1 PAT-TRAP® Trap Release Switch (See Diagram 11)
- Switch #2 Throw Arm Limit Switch. (See Diagram 9)
- Switch #3 Oscillation/Wobble Interrupter Activator Switch. (See Diagram 9)
- Switch #6 Interrupter Sequence Switch. (See Diagram 13)
- Switch #7 Interrupter Sequence Switch. (See Diagram 13)
- Switch #11 N/O Right-angle Limit Reed Switch. (See Diagram 10)
- Switch #12 N/O Left-angle Limit Reed Switch. (See Diagram 10)
- Switch #11A High-angle “UP” N/O Limit Reed Switch (Wobble). (See Diagram 12)
- Switch #12A Low-angle “DOWN” N/O Limit Reed Switch (Wobble). (See Diagram 12)

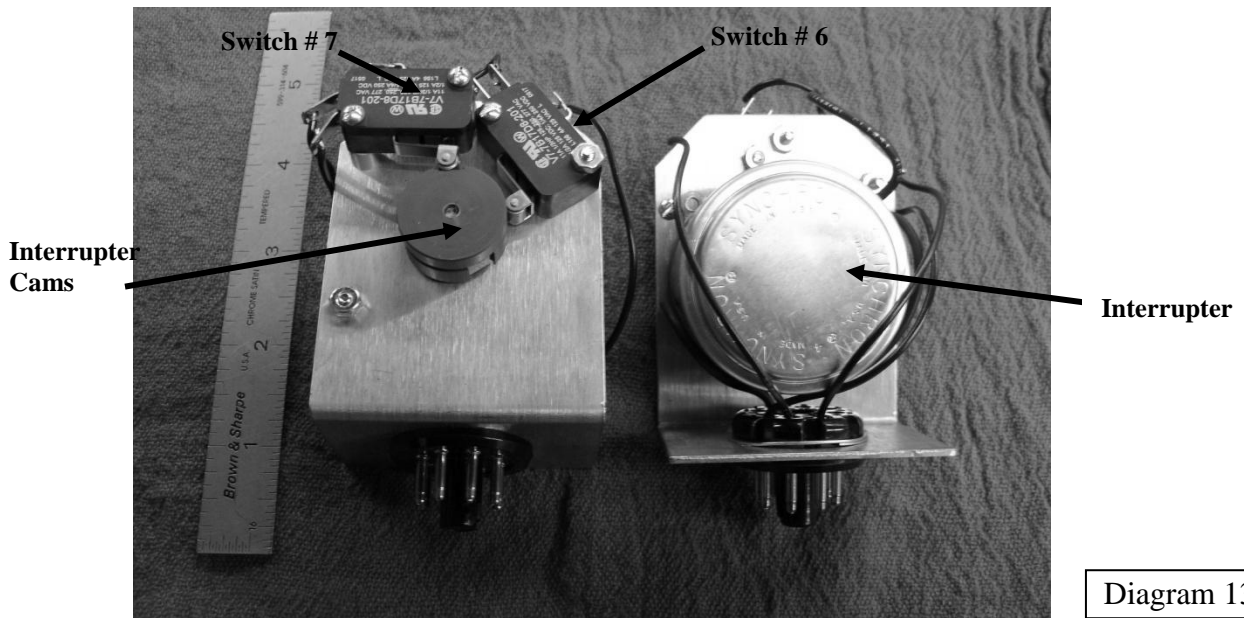

Diagram 13

Front and Rear Views of Interrupter (PT-9216) for PAT-TRAP®



TURNING THE PAT-TRAP® MACHINE “ON”

1. Push the Pump Motor toggle switch UP to the “ON” position. (Diagram 6)
2. **IMPORTANT:** Turn the pump motor switch on first so that the hydraulic system is pressurized to prevent any air from entering the system. Allow the pump to warm up the hydraulic oil before operating the machine. In warm weather this will not matter. **Cold temperatures may cause the throw arm to cycle repeatedly if the hydraulic oil is not warm.** Please refer to the section: Cold Weather Adjustment Temperature/Release Time and stopping the Throw Arm on the brake.
3. Push the On/Off/Release toggle switch UP to the “ON” position. (Diagram 6)

TURNING THE PAT-TRAP® MACHINE OFF

1. Standing outside, and to the side of the trap house, push the On/Off/Release toggle switch all the way DOWN to release and let go. The trap will throw the target and not cock the spring.
2. Push the Pump Motor toggle switch DOWN to the Off position.

LOADING THE PAT-TRAP® MACHINE

The Pat-Trap® machine holds four (4) full cases of clay targets. (540 Targets)

NEVER attempt to load the clay targets without first releasing the trap machine.

NEVER STAND IN FRONT OF A TRAP MACHINE. THE TRAP MACHINE MUST BE TURNED OFF AND THE SPRING RELEASED BEFORE ENTERING THE TRAP HOUSE. NEVER ATTEMPT TO MAKE ANY ADJUSTMENT WHILE THE THROW ARM IS COCKED.



PAT-TRAP, Inc.

Choice of the ATA

632 Western Avenue • Henniker, New Hampshire 03242 • Tel. (603) 428-3396 • Fax (603) 428-7340

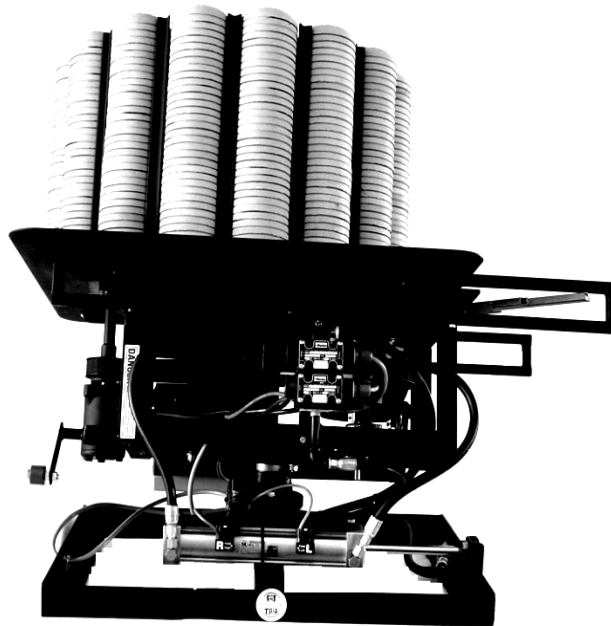
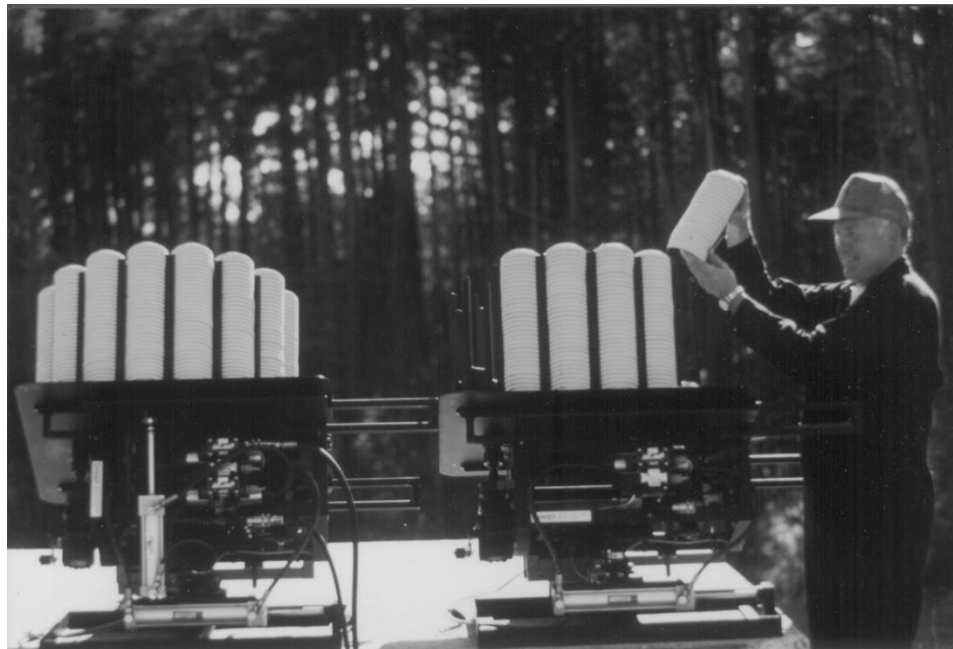

Diagram 14

Fully Loaded Pat-Trap[®] Machine



**Stuart W. Patenaude, the Inventor of the Pat-Trap[®],
loading an early Pat-Trap[®] Machine.**



AUTOMATIC PAT-TRAP® SINGLES

NEVER STAND IN FRONT OF A TRAP MACHINE. THE TRAP MACHINE MUST BE TURNED OFF AND THE SPRING RELEASED BEFORE ENTERING THE TRAP HOUSE. NEVER ATTEMPT TO MAKE ANY ADJUSTMENT WHILE THE THROW ARM IS COCKED.

1. Standing clear of the trap machine, release the target. Push the On/Off/Release toggle switch all the way down to the release position and then let go of it.
2. Pull back on the roller plate and move the set pin to the lower notch. (See Diagram 15)

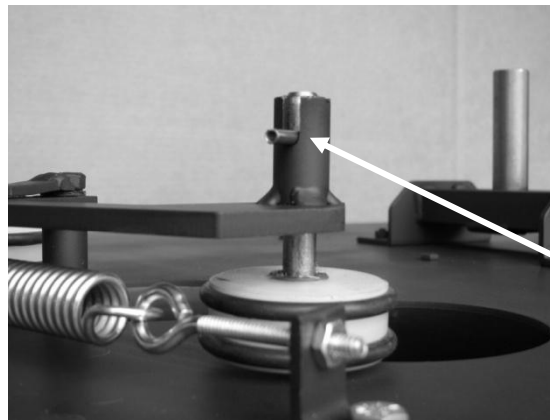

Diagram 15

Set Pin

Singles/Doubles Roller Plate in “Singles” Position

3. Set the Elevator Cog to the appropriate notch for singles. (Diagram 19)
4. The main spring tension can be adjusted by rotating the main spring crank clockwise to increase tension and counter-clockwise to reduce the tension. When changing from Doubles to Singles, rotate the main spring crank counter-clockwise the same number of turns that were used to increase the tension for Doubles --- approximately 10 rotations. (Diagram 16)



Main Spring
Crank Handle

Diagram 16



Main Spring Crank Handle

5. On the trap machine electrical box, the toggle switch must be pushed down to the Auto position. This will return the machine to automatic horizontal oscillation. (See Diagram 17)



Diagram 17

Electrical Enclosure (“Manual” Position)

6. Before exiting the trap house, staying clear of the trap, reach over to the power control box and release the target to prevent target releasing. (Diagram 6)
7. Standing outside of the trap house and to the side, push the On/Off/Release toggle switch up to the ON position. (Diagram 6)



AUTOMATIC PAT-TRAP[®] DOUBLES

NEVER STAND IN FRONT OF A TRAP MACHINE. THE TRAP MACHINE MUST BE TURNED OFF AND THE SPRING RELEASED BEFORE ENTERING THE TRAP HOUSE. NEVER ATTEMPT TO MAKE ANY ADJUSTMENT WHILE THE THROW ARM IS COCKED.

1. Standing clear of the trap machine, release the target. Push the On/Off/Release toggle switch all the way down to the release position and then let go of it.
2. Pull back on the Roller Plate and move the set pin to the upper notch. (Diagram 18)

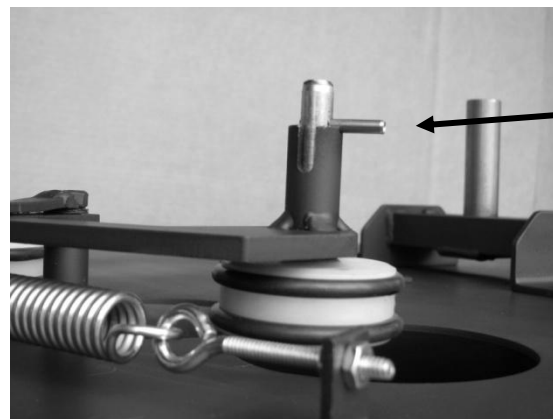

Set Pin

Diagram 18

Singles/Doubles Roller Plate in Doubles Position

3. Raise the elevation of the trap by placing the bottom portion of the trap machine into the elevation cog approximately 3-4 notches above the notch used to establish the Singles height. For example if the 10th notch was used in Singles then the Doubles setting should be approximately the 13th or 14th notch on the Elevation Cog nearest the frame. (Diagram 19)

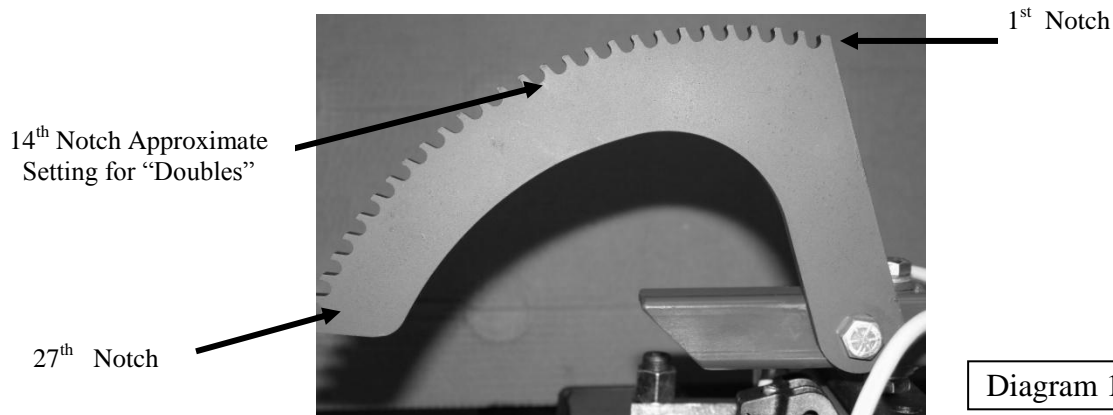

Diagram 19

Elevation Cog



4. The spring tension must be *increased* to throw Doubles. Rotate the spring crank *clockwise* approximately 10 rotations from the Singles setting. (Diagram 16).
5. On the trap machine electrical box, the toggle switch must be pushed up to the Manual position (Diagram 17). This will stop the automatic horizontal oscillation and will activate the Right and Left pushbuttons. The trap machine must be ON to operate the Right and Left pushbuttons. When the trap is On the throw arm is ready to fire. The throw arm can be fired by pushing the pullcord button. It can also be fired by hand: by pushing the arm forward off the brake when the machine is either On or Off. Staying clear of the trap machine, reach over to the power control box and turn the On/Off/Release switch to the ON position.
6. Use the Right or Left button to move the trap machine to the center of the trap field.
7. Before exiting the trap house, staying clear of the trap, reach over to the power control box and release the target.
8. Standing outside of the trap house and to the side, push the On/Off/Release toggle switch up to the ON position.

ADJUSTMENT FOR PAT-TRAP® DOUBLES

The adjustment for Doubles should only need to be done the very first time the machine is used. Using a 7/16” wrench, loosen the bolt, move the Double Finger in 1/8” increments. Pull the Doubles Finger back towards self to lower the height of the right target. Push it forward to raise the height of the right target. Tighten the bolt. See Diagram 20. Refer to the section for correct positioning of the Doubles Finger (Page 37). (Although the bolt is snug, it is possible to move the Doubles Finger without loosening the bolt.)

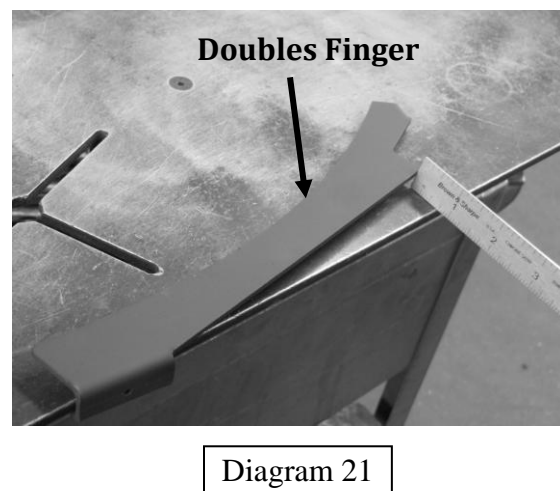
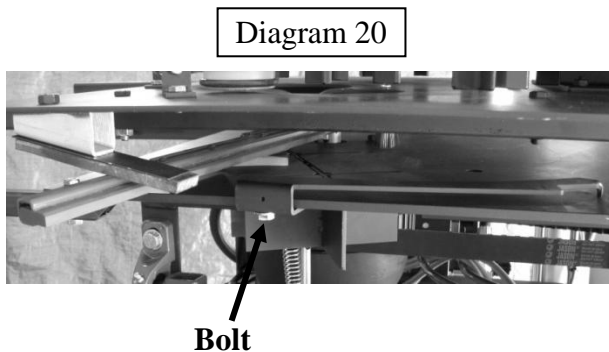



AUTOMATIC PAT-TRAP® WOBBLE SETTINGS

The PAT-TRAP® with Wobble can be used in any of the following modes:

STATIONARY

X Singles
X Doubles

OSCILLATING HORIZONTAL

X Singles
X Doubles

OSCILLATING VERTICAL

X Singles
X Doubles

OSCILLATING HORIZONTAL/VERTICAL

X Singles
X Doubles

The PAT-TRAP® with Wobble has an interrupter for the horizontal and vertical modes.

NOTE: If the machine is located inside a trap house, oscillating doubles targets may hit the trap house walls.

WOBBLE ANGLES

Left/Right Angle = 8" => 50°
Down Angle = 7° Min

Left/Right Angle = 10" = 60°
Up Angle = 25 ½ ° Max

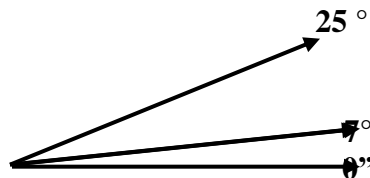



CHANGE OVER TO WOBBLE

Standing clear of the trap machine, release the target. Use all safety procedures as stated in the previous Singles and Doubles section of this Manual.

The Oscillation Switch and the Wobbles Switch must be pushed down to the AUTO position on the trap machine electrical enclosure. This engages the machine to the automatic horizontal/vertical oscillation mode.



Diagram 22

HEIGHT ADJUSTMENT FOR SINGLES/DOUBLES ON A WOBBLE MACHINE

On the trap machine electrical box, the horizontal switch must be moved to the MANUAL position. For desired height, push UP switch to go up; push DOWN switch to go down.



INCREASING/DECREASING TARGET DISTANCE/SPEED

Clockwise rotation of the main spring crank handle increases the spring tension thus increasing the speed of the target and the distance it travels.

Counter clockwise rotation of the main spring crank handle decreases the spring tension. Continued counter-clockwise rotation will remove the tension from the crank and the spring tension lock-nut will hold. The elastic lock-nut holds the spring at the set minimum tension.

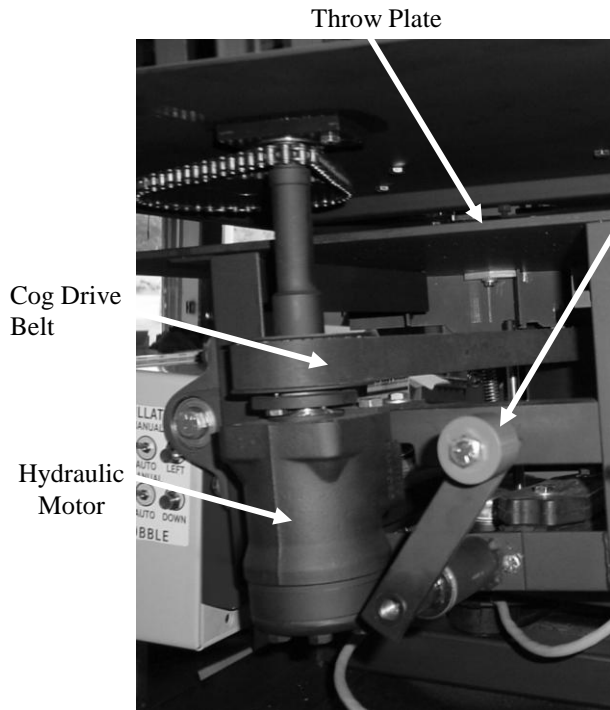

Diagram 23

Main Spring
Crank Handle
PT-9031



Diagram 24

PAT-TRAP® Main Spring Crank Handle



SETTING MINIMUM TARGET DISTANCE

The procedure to establish the minimum distance for a “Singles” target is as follows: (the standard trap speed is 67 to 70 FPS to throw a target 49 to 51 yards with the machine angled at 20 degrees (9 ft high and 30 ft out) (For a 45 yard Doubles target set a Single target at 76 FPS). (Call Pat-Trap, Inc. about the Target Speed Chronograph system for measuring speed.)

1. Remove the main spring crank handle by rotating it counter-clockwise (Diagram 25).
2. Remove the nylon washer that is sandwiched between the crank handle and the stand-off collar sleeve (Diagram 25).

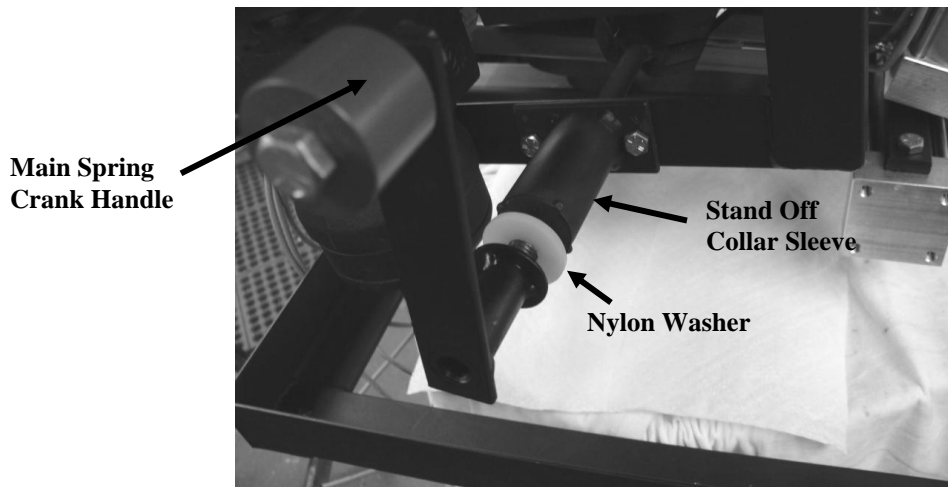

Diagram 25

Backing off the tension on PAT-TRAP® Main Spring Crank Handle

3. Remove the two (2) 1/4” bolts from the stand-off collar sleeve (Diagram 26)

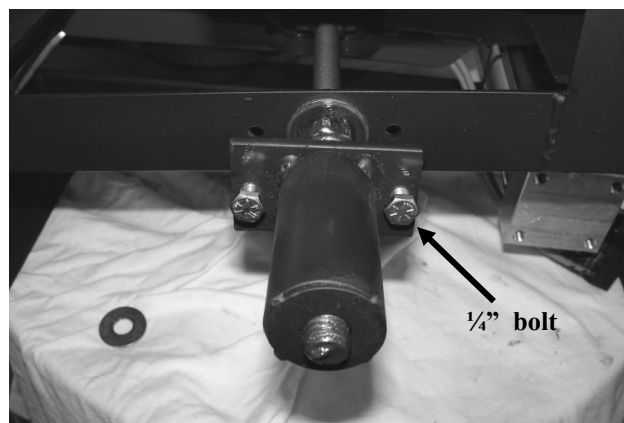

Diagram 26

Removing Main Spring Standoff Collar Sleeve

4. Remove the stand-off collar sleeve (Diagram 26).



5. Locate the elastic lock-nut. Use a $\frac{3}{4}$ " wrench on this nut to adjust the distance/speed (Diagram 27)

$\frac{1}{2}$ -13
Elastic
Lock Nut



Diagram 27

Adjusting Elastic Lock Nut with $\frac{3}{4}$ " Wrench

6. At this point one can throw a target or two to establish how far the PAT-TRAP[®] is currently throwing a straight away "Singles" target. Please observe the proper safety precautions.
7. When proper/desired distance/speed is achieved, back off the elastic lock-nut three (3) turns.
8. Re-assemble the parts.
9. When the main spring crank handle becomes snug, continue to turn three (3) more times for the proper setting.
10. Note: Whenever a "Singles" distance is to be set, back off the crank to neutral, crank back to snug; then give another three (3) turns for proper setting.

NEVER STAND IN FRONT OF A TRAP MACHINE. THE TRAP MACHINE MUST BE TURNED OFF AND THE SPRING RELEASED BEFORE ENTERING THE TRAP HOUSE. NEVER ATTEMPT TO MAKE ANY ADJUSTMENT WHILE THE THROW ARM IS COCKED.

NOTE: "SINGLES" are always set first, and then follow the procedures for "Doubles" as outlined.



ADJUSTMENT HEIGHT OF TARGETS

NEVER STAND IN FRONT OF A TRAP MACHINE. THE TRAP MACHINE MUST BE TURNED OFF AND THE SPRING RELEASED BEFORE ENTERING THE TRAP HOUSE. NEVER ATTEMPT TO MAKE ANY ADJUSTMENT WHILE THE THROW ARM IS COCKED.

Tilt the table by pushing up on the front of the machine. The elevation cog can be positioned up or down.

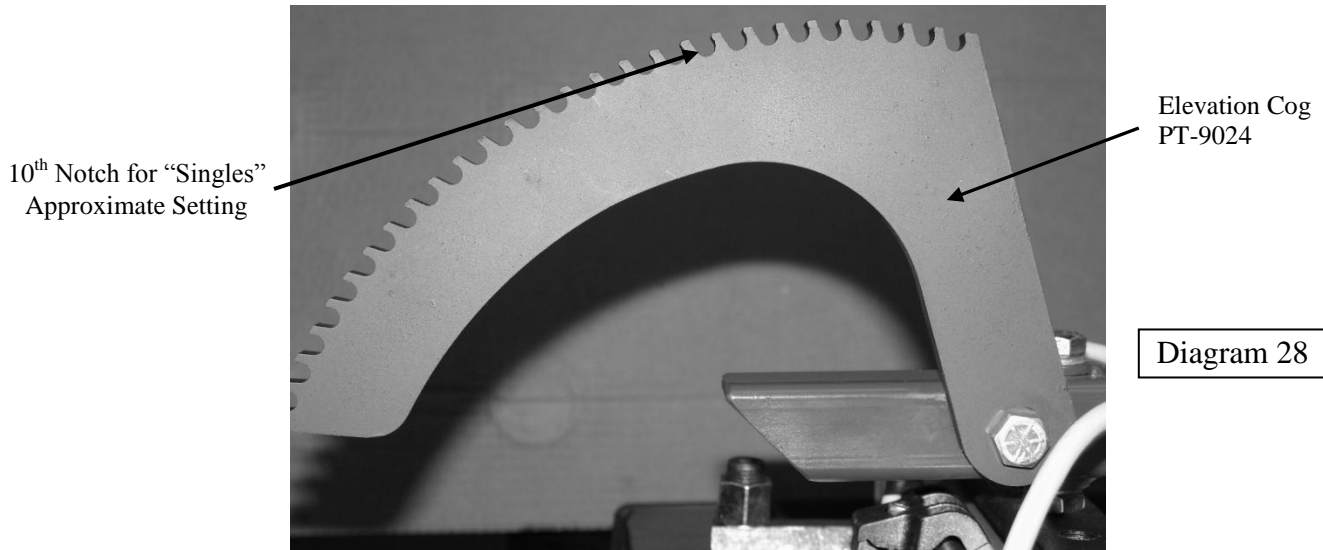

Elevation Cog on Front of PAT-TRAP®



ANGLE ANDJUSTMENTS

STRAIGHT-AWAY TARGETS

Set the toggle switch to the manual position, Use the right and left buttons to achieve Straight-Away Targets.



Diagram 29

Toggle Switch

2 – HOLE TARGETS

The 4 1/4” spacer bar between the Left and Right Angel Reed Switches allows for a 5 7/8” of total cylinder rod travel, which equals a **Two-Hole (34°)** Target.

A 5 1/4” spread between the switches allows for a 6 7/8” of total cylinder rod travel, which equals a **Three-Hole (40°)** Target.



2-Hole
Spacer Bar

#12 Left Angle
Limit Switch (N.O.)
PT-9222

Diagram 30

#11 Right Angle
Limit Switch (N.C.)
PT-9223



PAT-TRAP, Inc. ***Choice of the ATA***

632 Western Avenue • Henniker, New Hampshire 03242 • Tel. (603) 428-3396 • Fax (603) 428-7340

SHIFTING THE TARGET FIELD

The 9/64” hex head set screws on the limit switches are already pre-set.

DO NOT OVERTIGHTEN AS THE PLASTIC BRACKET WILL BREAK!

An aluminum spacer bar that is 4 ¼” long is provided for setting a “2-Hole” target field width (See Diagram 30). The field can be adjusted by sliding the limit switches together with the spacer bar in the direction you want to move the field;

TO MOVE THE ENTIRE FIELD TO THE RIGHT, SLIDE THE SWITCHES TO THE RIGHT AS YOU ARE FACING THE MACHINE. Keep the switches against the spacer bar to maintain the proper field width. The set screws are lightly set so that you can slide the limit switches without adjusting the set screws.

To be able to go back to the original setting use a magic marker to draw a line on the cylinder beside the switch to mark where the switches should go back to.



POSITION OF THE ROLLER PLATES

The roller plate must be positioned as shown. The measurement to both of the roller plates is taken from the face of the kingpin shaft to the inside edge of the roller wheel bolt. See Diagram

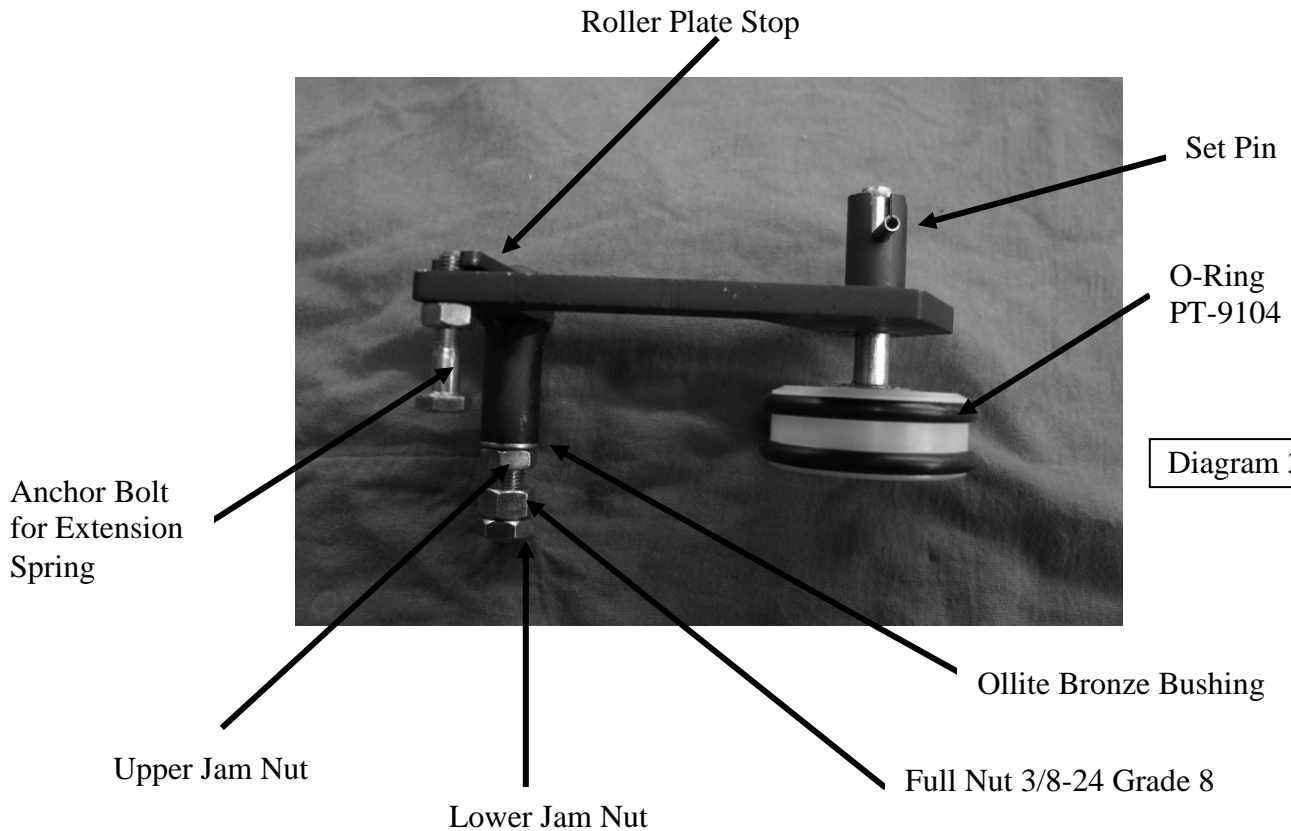

If an adjustment is necessary, then the roller plate stop will have to be turned until the roller plate stops at the given measurement.

To set the position of the roller plate stop:

1. Remove the extension spring
2. Adjust upper jam nut so that when the nut is tightened the roller plate will pivot freely: with no more than 1/32" of up/down play between the roller plate shaft and jam nut.
3. Use an adjustable wrench to turn the roller plate stop to the correct position,
4. Hold back on the roller plate stop with the adjustable wrench while tightening the Full nut. Torque nut to 35/40 ft/lbs.
5. Tighten jam nut against full nut while holding back against the roller plate stop with the adjustable wrench. Torque jam nut to approximately 15 ft/lbs.
6. Check for free pivot of the roller plate after tightening.
7. Reconnect the extension spring.
8. Check the measurement to each roller plate from the king pin.



Extension
Spring

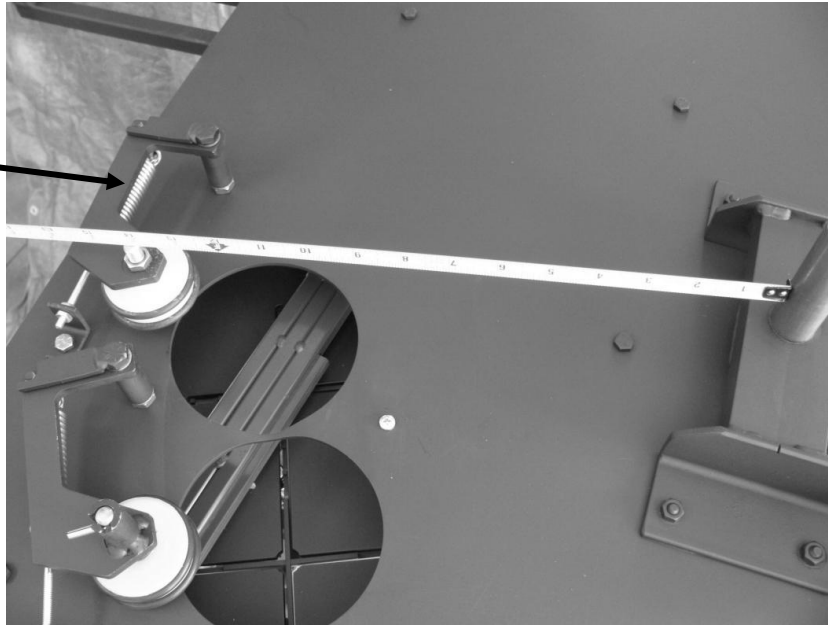

Diagram 32

13 7/8"

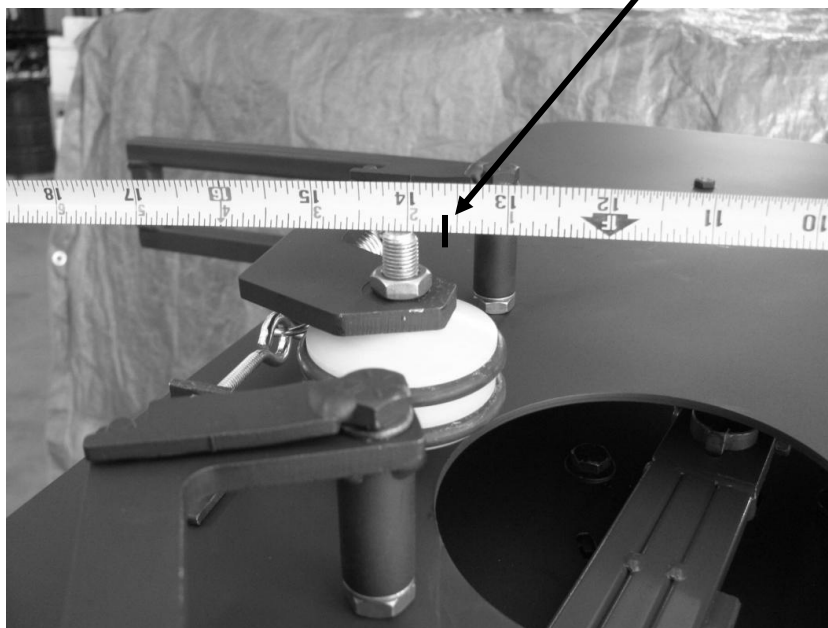

Diagram 33

Singles Roller Plate measurement is 13 7/8" from face of Kingpin Shaft to inside face of the Single Roller Wheel bolt.

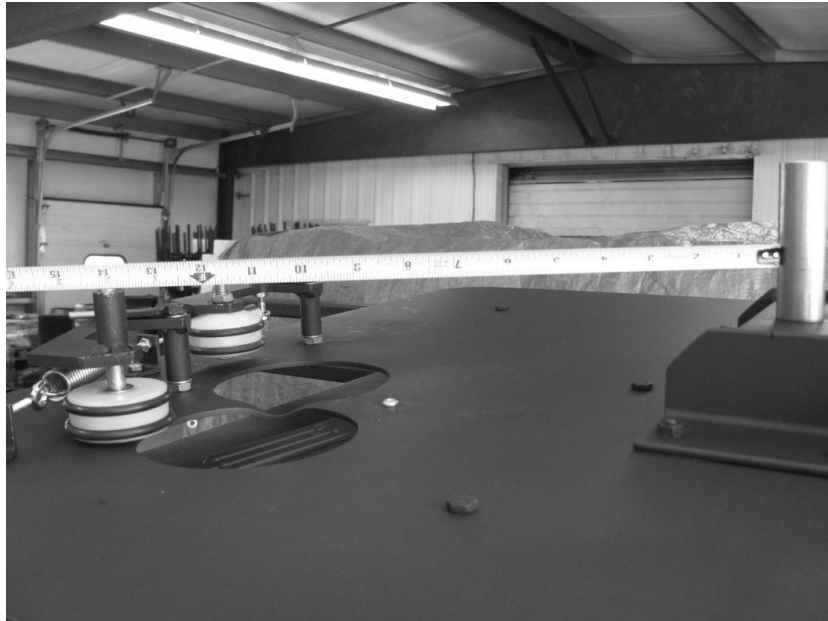

Diagram 34

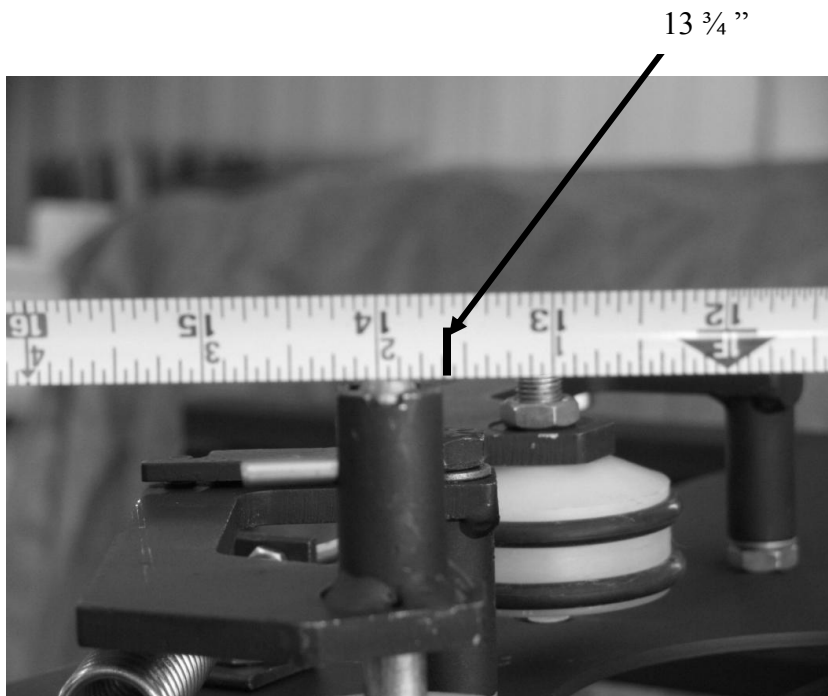

Diagram 35

Doubles Roller Plate measurement is 13 ¾” from the face of the Kingpin Shaft to the inside face of the Doubles Roller Wheel bolt.



TARGET BRUSH MAINTENANCE

When Targets start to break or Targets are being thrown further to the right, it may be time to change the target brush. When the target brush becomes worn out, the target can be bumped ahead and/or “slide down” the throw plate. This can cause either the target to break or be thrown further to the right.

The purpose of the target brush is to hold the target against the throw arm when the throw arm advances to the cocked position.

When the brush begins to “flair out”, loosen the screw and turn the brush 180 degrees. The brush needs to be aligned with the narrow side of the brush running from front to back of the Pat-Trap[®] Machine as shown in Diagram 36 below. Replace the Target Brush when needed.

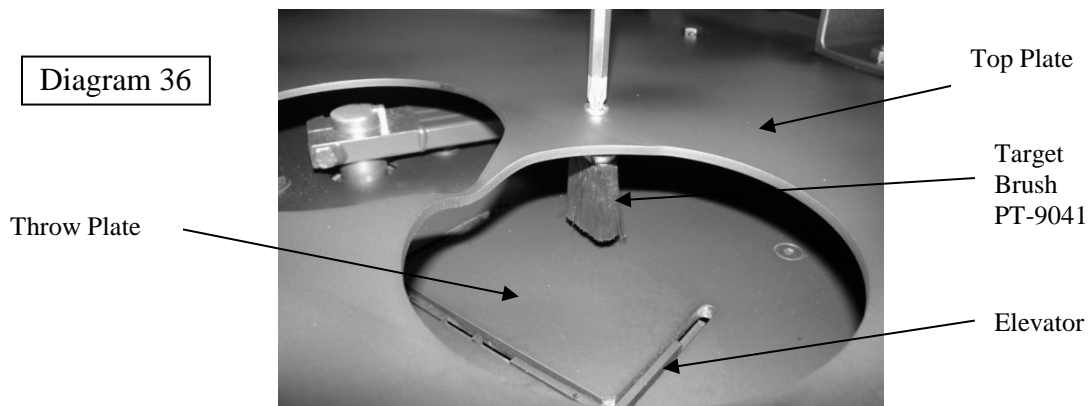

Installation of New Target Brush

The turret does not have to be removed to replace the target brush. Just remove the targets and use a phillips screw driver to remove the brush.



COLD WEATHER ADJUSTMENT TEMPERATURE/RELEASE TIME STOPPING THE THROW ARM ON THE BRAKE

NEVER STAND IN FRONT OF A TRAP MACHINE. THE TRAP MACHINE MUST BE TURNED OFF AND THE SPRING RELEASED BEFORE ENTERING THE TRAP HOUSE. NEVER ATTEMPT TO MAKE ANY ADJUSTMENT WHILE THE THROW ARM IS COCKED.

In very cold weather, the pump motor should be turned on 30 to 60 minutes before operating time to warm up the hydraulic oil. If the On/Off/Release switch is turned on too soon, the machine will keep cycling (throwing targets).

Extreme temperature changes may affect the stopping position of the throw arm. Very cold temperature may cause the machine to keep cycling by itself. Very warm weather may cause the throw arm to stop too soon and cause slow pulls.

Refer to the Diagram 37 which shows the throw arm brake assembly and the proper stopping position of the throw arm. Note: The Throw Arm is approximately 1" back from the right edge of the Throw Arm Brake Rubber Pad.



Diagram 37

Correct Position for Stopping the Throw Arm on the Throw Arm Brake



ADJUSTING RELEASE TIME - CORRECTION OF CYCLING PROBLEM

To Adjust the Release Time, Correct a Cycling Problem, or Compensate for Extremely Cold Weather.

1. NEVER STAND IN FRONT OF A TRAP MACHINE. THE TRAP MACHINE MUST BE TURNED OFF AND THE SPRING RELEASED BEFORE ENTERING THE TRAP HOUSE. NEVER ATTEMPT TO MAKE ANY ADJUSTMENT WHILE THE THROW ARM IS COCKED.
2. Locate the two switches (#2 & #3 Micro Roller Switches) on the bottom left side of the trap machine which are mounted on an adjustable bracket. Diagram 38.
3. Loosen the thumb screw to allow the switch bracket to move forwards or backwards. Diagram 39.
4. Move the upper portion of the switch bracket (diagram 39) by increments of 1/16" to the left (forward towards the front of the trap house) to stop cycling --- or lengthen the throw time --- causing the arm to stop further back on the throw arm brake.
5. To shorten the throw time (release time), move the switch bracket to the right --- toward the back of the trap house --- causing the throw arm to stop further forward on the brake.
6. For proper stopping position of the throw arm on the brake see Diagram 37.

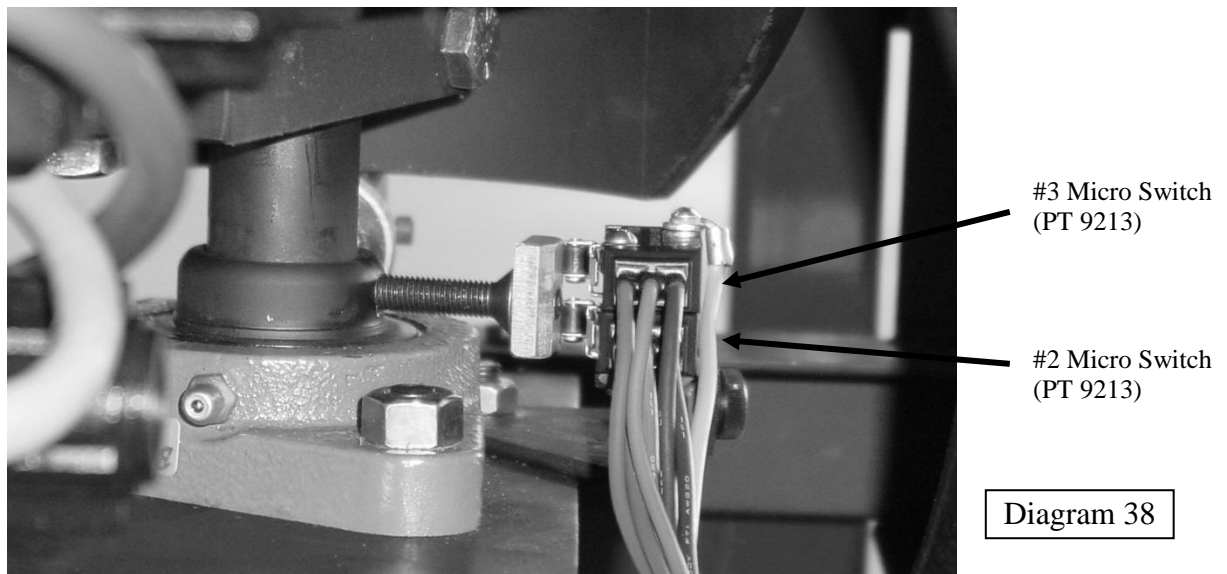

Side View of #2 & #3 Switch Bracket shown on Activator Cam



Activator Cam

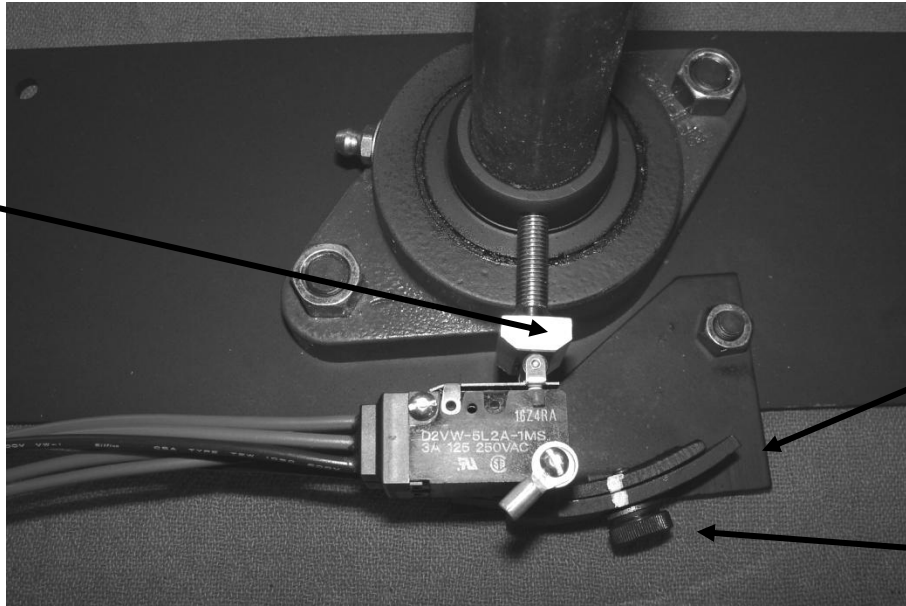

Switch Bracket

Diagram 39

Thumb Screw

Top View of #2 & #3 Switch Bracket shown on Activator Cam



ASSEMBLY AND MAINTENANCE OF THE THROW ARM BRAKE

A worn out brake rubber or broken brake flat spring will allow the throw arm to fire through (i.e., cycle) thereby throwing uncalled for targets.

Keep surfaces dry where the throw arm contacts the brake rubber.

Replace the throw arm brake rubber when it begins to wear out. See Diagram 4.4.

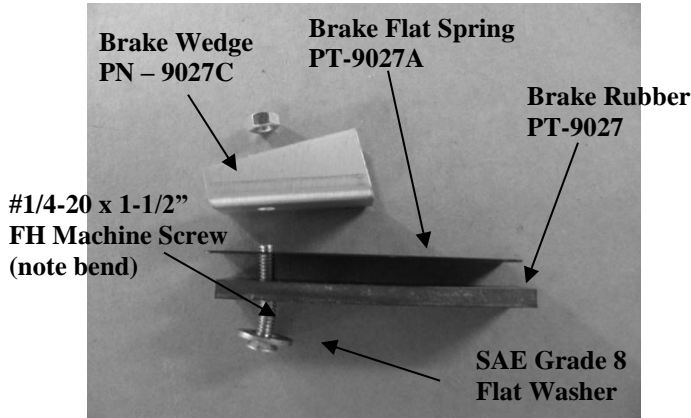

Diagram 40

Components of Throw Arm Brake Assembly

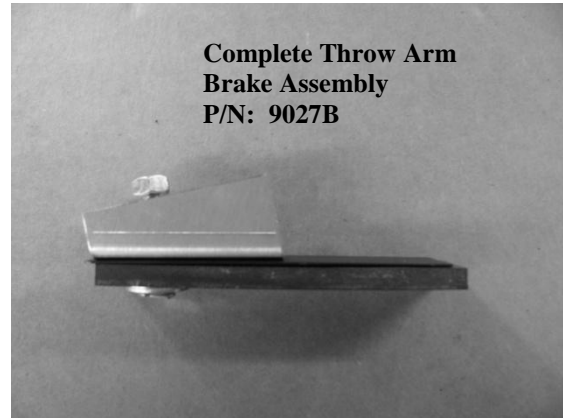

Diagram 41

NOTE: The proper stopping position for the throw arm on the throw arm brake is shown in Diagram 42, which is approximately one inch from the right hand side of the brake rubber.



Throw Arm Brake Assembly P/N – 9027B

Diagram 42

Throw Arm in "Cocked Position" on Throw Arm Brake Assembly



REMOVAL OF THROW ARM

NEVER STAND IN FRONT OF A TRAP MACHINE. THE TRAP MACHINE MUST BE TURNED OFF AND THE SPRING RELEASED BEFORE ENTERING THE TRAP HOUSE. NEVER ATTEMPT TO MAKE ANY ADJUSTMENT WHILE THE THROW ARM IS COCKED.

1. Remove and/or disconnect the main spring. Refer to the **Disconnecting The Uni-Band** section in this manual (Page 34).
2. Rotate the throw arm to a place where you can reach the nut. Use a 7/16th socket wrench with a long extension to loosen the 1/4-28 nut on the throw arm (See Diagram 43).
3. Move the arm to the area between the braces. Use a pry bar or a long screwdriver. Place it under the throw arm next to the throw arm shaft and pry up on the throw arm to remove.
4. NOTE: The arm might come off more easily if you wiggle the throw arm, slightly, up and down while prying up.
5. Pry downwards against the underside of the top plate to install the new throw arm.

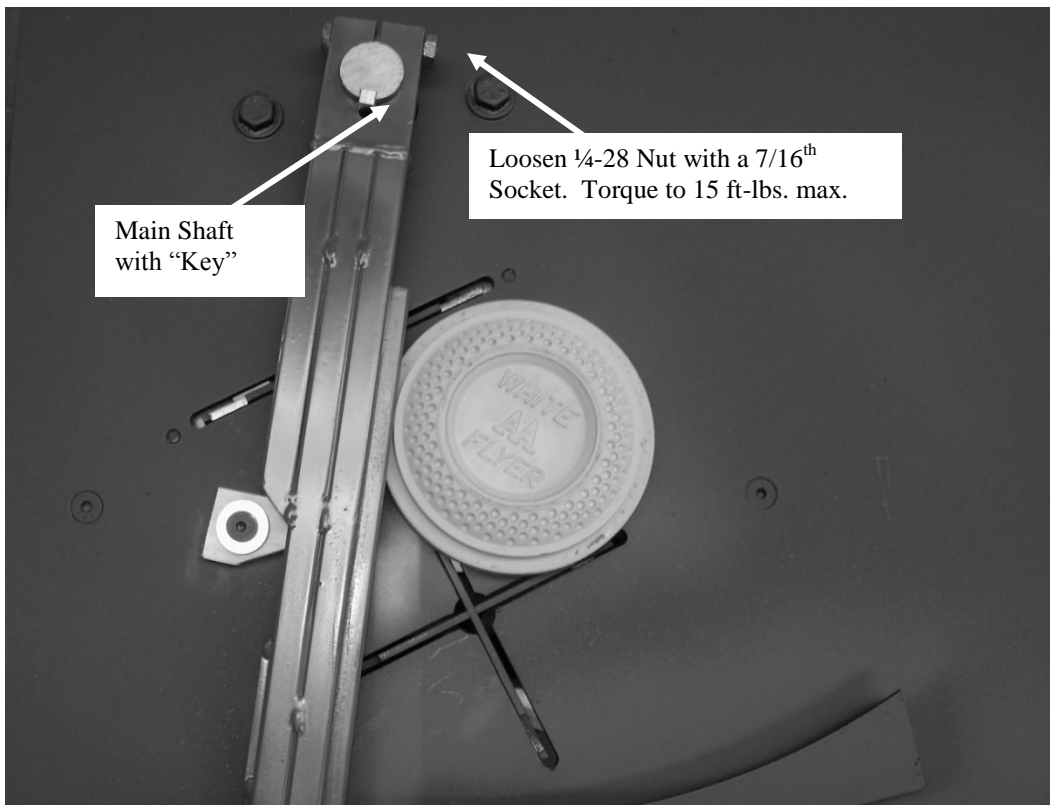

Diagram 43

Removal/Installation of Throw Arm (PT-9026)



DISCONNECTING THE UNIBAND FROM THE CLUTCH

1. Let off the crank handle tension.
2. Turn the machine on to cock the throw arm.
3. When the throw arm stops at the throw arm brake, turn the machine off without releasing the throw arm.
4. **WHEN THE THROW ARM IS COCKED, BE SURE TO STAND BEHIND THE TRAP AND STAY CLEAR OF THE THROW ARM.** To completely release the tension on the throw arm carefully, manually, release the throw arm by first looping a rope or cord around the end of the throw arm. Then, holding back on the rope at 90 degrees to the throw arm, slowly move the throw arm past the brake and guide it around to the front of the machine.
5. Move the throw arm so that it is $6 \frac{7}{8}$ " from the right hand corner of the throw plate. See Diagram 53.
6. Use a $\frac{5}{32}$ " allen wrench to loosed the clutch rod-end bolt. Pull down on the rod end to remove. See Diagram 52.

INSTALLATION OF THE THROW ARM

1. Release the throw arm. Never attempt to work on your machine while it is in the cocked position.
2. Turn off the machine and “drop” the machine to the lowest elevation for an easier working position.
3. Disconnect the main spring before working with the throw arm. Refer to the Disconnecting the Uni-Band section in this manual.
4. Place the throw arm on the main shaft in the same place that it was. Hold the throw arm level while tightening the $\frac{1}{4}$ -28 nut.
5. The height of the bottom of the throw arm rubber needs to be $\frac{1}{2}$ -inch above the surface of the throw plate. (This measurement allows for $\frac{1}{32}$ " between the lip of the target and the throw arm rubber.) See Diagram 44 & 45.

Note: Bottom of Throw Arm Rubber is $\frac{1}{2}$ " Above Throw Plate Surface in the area where the target leaves the throw plate.

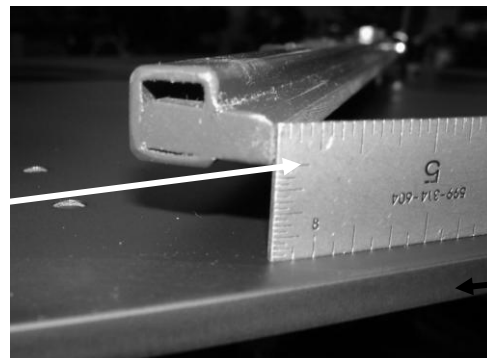

Throw Plate

Diagram 44

Setting Correct Height of Throw Arm with a Ruler



6. With the main spring disconnected, check to be sure that there is $1/32$ " , but no more than $1/16$ " , of clearance between the target and the throw arm through the area that the target travels --- especially the area where the target leaves the throw plate surface. Please refer to Diagram 45.



Diagram 45

Setting Correct Target Clearance for Throw Arm with a Target

7. Check to see that the notch on the front rake on the PAT-TRAP[®] throw arm clears the Doubles Finger. See Diagram 46. To verify the clearance, move the throw arm manually past the brake and through the area of the Doubles Finger to check clearance.
8. If necessary, the Doubles finger can be bent down using a pair of channel-lock pliers. A screwdriver can be used between the "doubles" finger and the throw plate to pry it up if necessary.

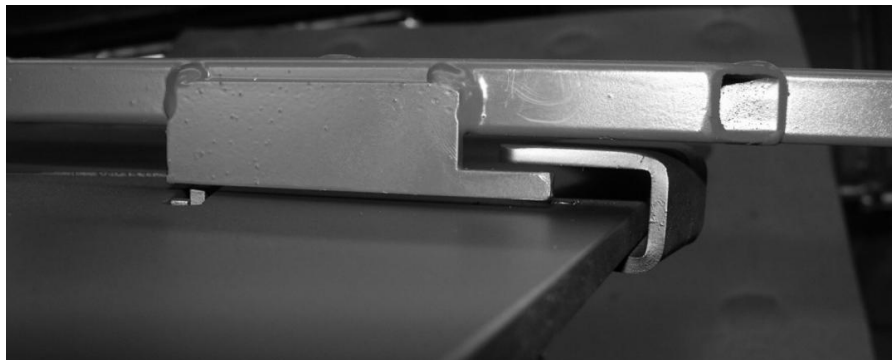

Diagram 46



MAINTENANCE OF THROW ARM COCKING PIN

The PAT-TRAP[®] machine must be released and turned off before performing any work.

Rotate the bumper 45 degrees (1/8th turn) after approximately 100,000 throws (see counter located in the Electrical Control Box) to see if a flat spot is visible. The bumper should be easy to rotate by hand without having to loosen the bolt. Replace the bumper if worn or cracked. Slide the new bumper onto the bolt as pictured in Diagram 47.

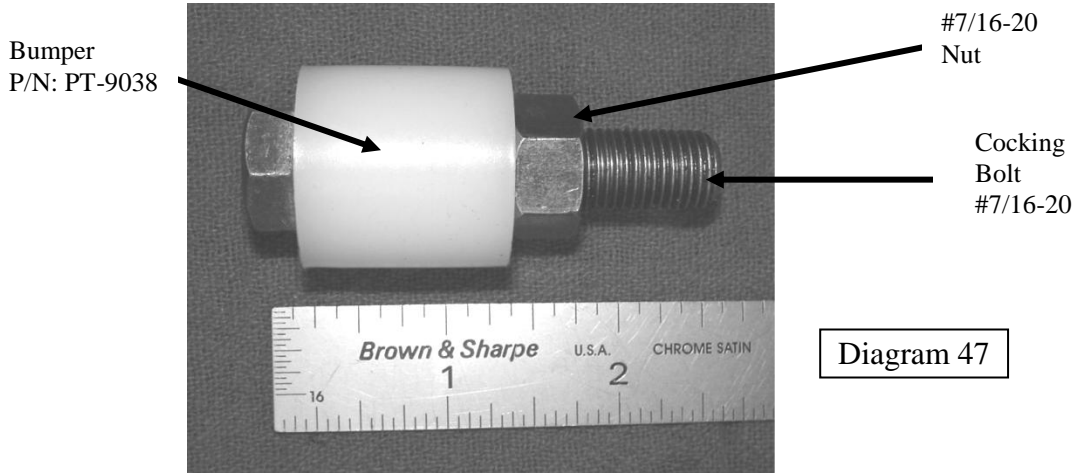

Cocking Bolt Assembly (PT-9035)

Turn the nut on by hand until it is against the bumper.
Screw the Cocking Pin Assembly into the bottom of the main cog belt pulley wheel until the nut contacts the wheel. See Diagram 48.
Now, tighten the nut against the main timing wheel very tight. (Torque to 35-40 ft-lbs.).
See Diagram 48 below.

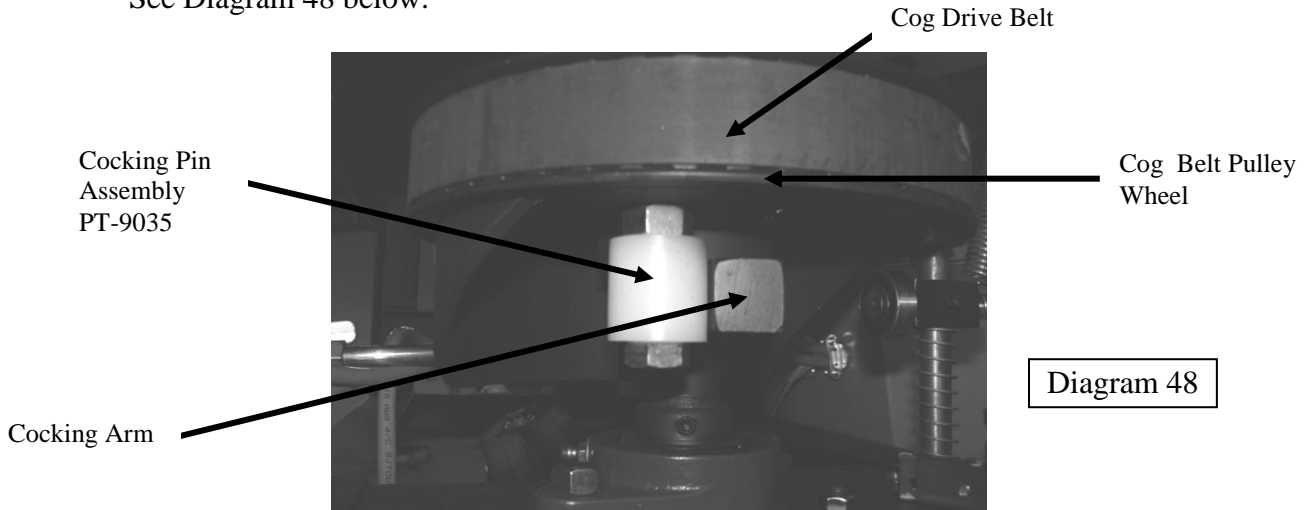

Cocking Bolt Assembly (PT-9035) Attached to Timing Pulley

IMPORTANT: Do not tighten the bolt against the nut because it will compress the bumper.



INSTALLATION OF THE “XXX” DOUBLES FINGER

1. Release the throw arm and turn off the machine.
2. Set the “XXX” Doubles Finger so that the corner of the first step measures approximately $\frac{3}{4}$ ” inside the edge of the Throw Plate. Tighten the bolt. This is the approximate position of the “XXX” Doubles Finger for level double targets. See attached diagram 49.

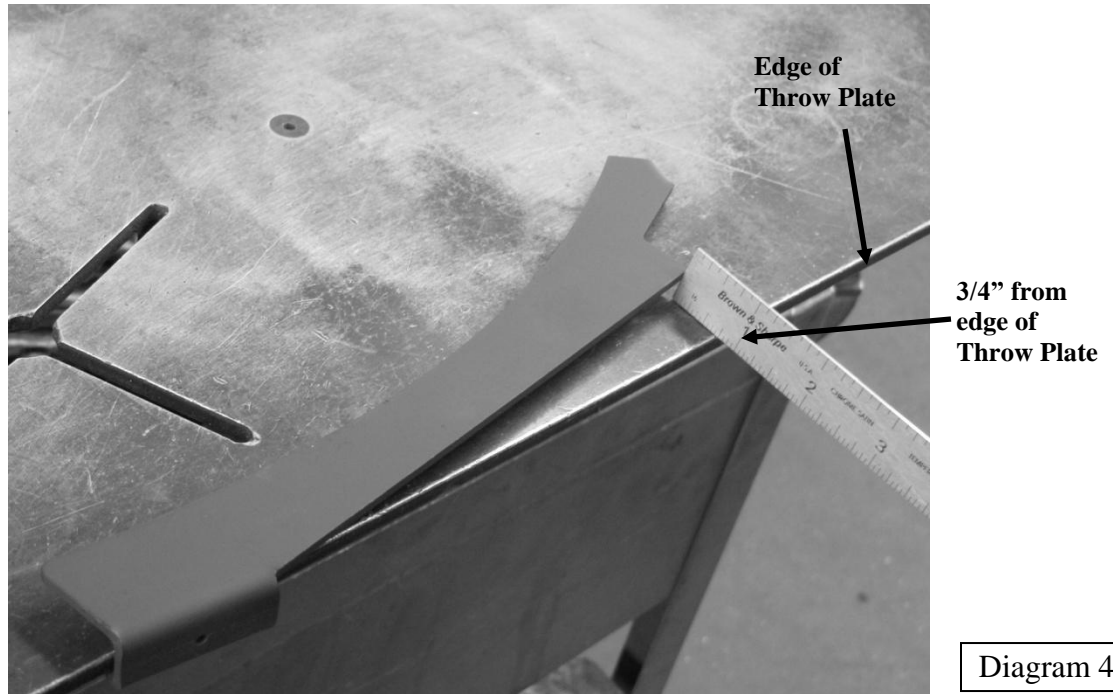

3. Check to make sure that the Singles Finger measures $4 \frac{3}{8}$ ” from the left-hand end of the “XXX” Doubles Finger. When tightening the nut, hold back on the Singles Finger so that it does not rotate upwards. Diagram 50.

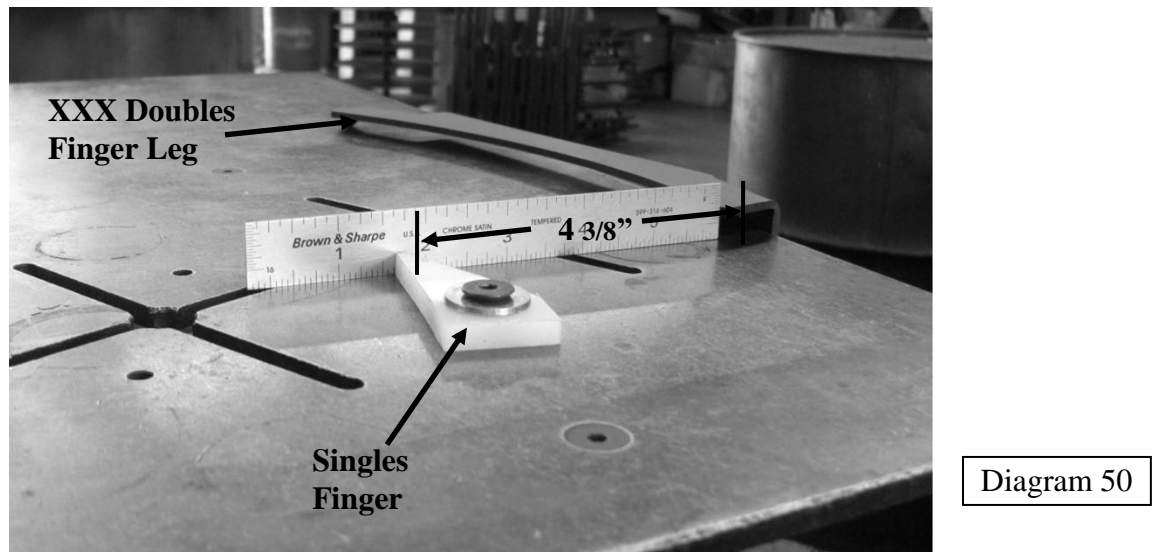



4. Check to see that the Throw Arm clears the “XXX” Doubles Finger.
 - a. Reduce the main spring tension – unwind the crank handle
 - b. Disconnect the main spring – refer to this section in your Machine Manual (page 34).
 - c. Move the Throw Arm manually past the Brake and through the area of the ”XXX” Doubles Finger to check the clearance. Water-pump pliers can be used if the “XXX” Doubles Finger needs to be pried downwards. A long screwdriver can be used if the “XXX” Double Finger needs to be pried upwards.

Presuming the machine is sitting on a level platform, with no wind; these directions should yield a level pair of Doubles.

When installing the XXX Doubles Finger check to make sure that the leg is contacting the Throw Plate surface. If it is not, then remove the finger from the machine and bend down slightly at the opposite end of the finger. (Diagram 50).



REPLACEMENT/REMOVAL OF MAIN SHAFT CLUTCH ASSEMBLY (PT-9034)

NEVER STAND IN FRONT OF A TRAP MACHINE. THE TRAP MACHINE MUST BE TURNED OFF AND THE SPRING RELEASED BEFORE ENTERING THE TRAP HOUSE. NEVER ATTEMPT TO MAKE ANY ADJUSTMENT WHILE THE THROW ARM IS COCKED.

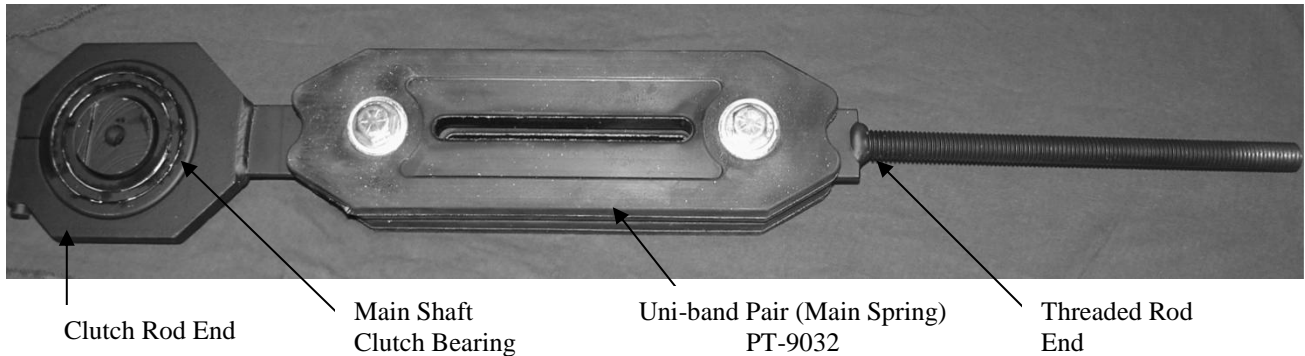

Diagram 51

Main Shaft Clutch Assembly (PT-9034)



Diagram 52

Clutch Rod End of Main Shaft Clutch Assembly



PAT-TRAP, Inc. *Choice of the ATA*

632 Western Avenue • Henniker, New Hampshire 03242 • Tel. (603) 428-3396 • Fax (603) 428-7340

1. Back off the tension on the Main Spring crank handle by rotating it counter clockwise.
2. Turn the machine on to cock the throw arm.
3. When the throw arm stops at the throw arm brake, turn the machine off without releasing the throw arm.
4. **WHEN THE THROW ARM IS COCKED, BE SURE TO STAND BEHIND THE PAT-TRAP® AND STAY CLEAR OF THE THROW ARM.** To completely release the main spring tension on the throw arm carefully, manually, release the throw arm by first looping a rope or cord around the end of the throw arm. Then, holding back on the rope at 90 degrees to the throw arm, slowly move the throw arm past the brake and guide it around to the front of the machine.
5. Move the throw arm so that it is 6 7/8" from the right hand corner of the throw plate. (Diagram 53.)

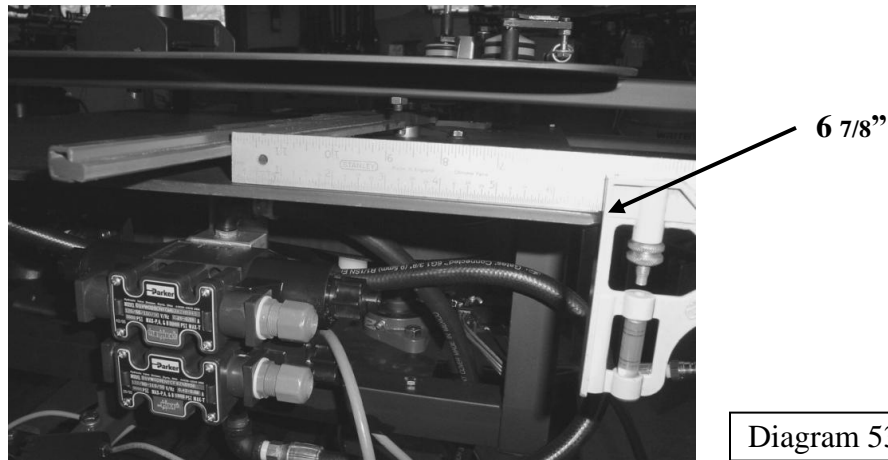

Positioning Throw Arm When Installing Main Shaft Clutch Assembly

6. Clamp a vise-grip onto the throw plate with the throw arm at 6 7/8" to prevent the throw arm from moving forward. See Diagram 54.

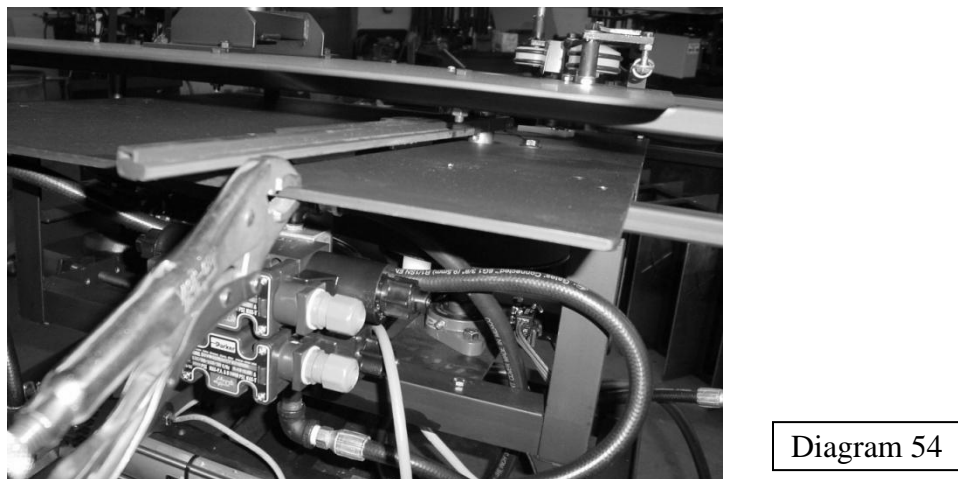

Securing the Position of the Throw Arm at 6-7/8"



7. Remove the main spring crank handle from the threaded rod by rotating it counter clockwise.

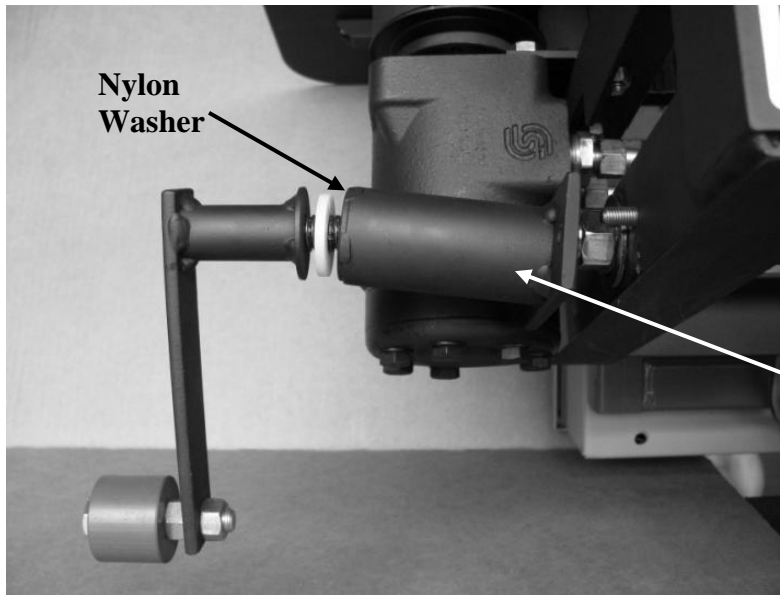

Diagram 55

Backing off the tension on PAT-TRAP® Main Spring Crank Handle

8. Remove the nylon washer that is sandwiched between the crank handle and the stand off collar sleeve (See Diagram 55).
9. Remove the two (2) 1/4" bolts from the stand off collar sleeve (See Diagram 56)

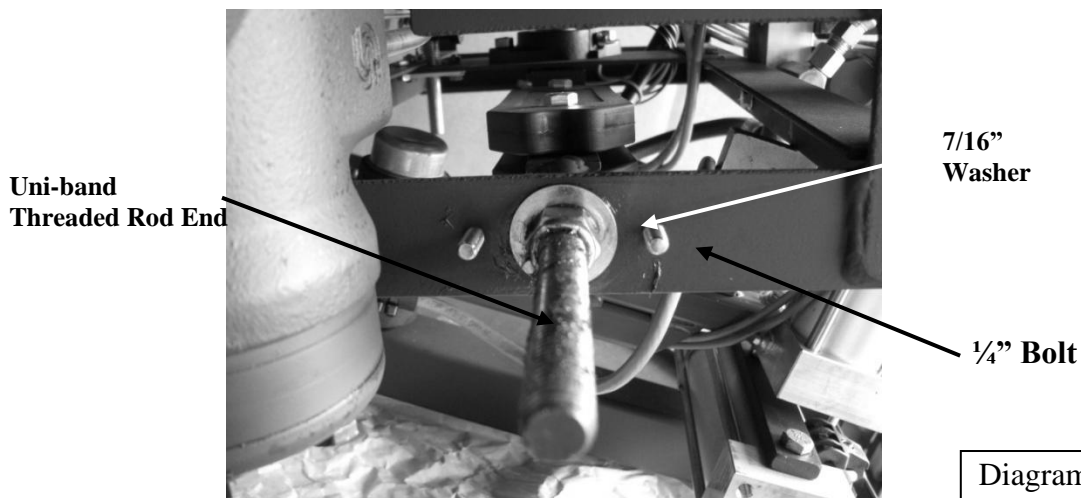

Diagram 56

Removing Main Spring Standoff Collar Sleeve

10. Remove the stand off collar sleeve (See Diagram 55).
11. Locate the elastic lock-nut. Use a 3/4" wrench to remove this nut (See Diagram 57).

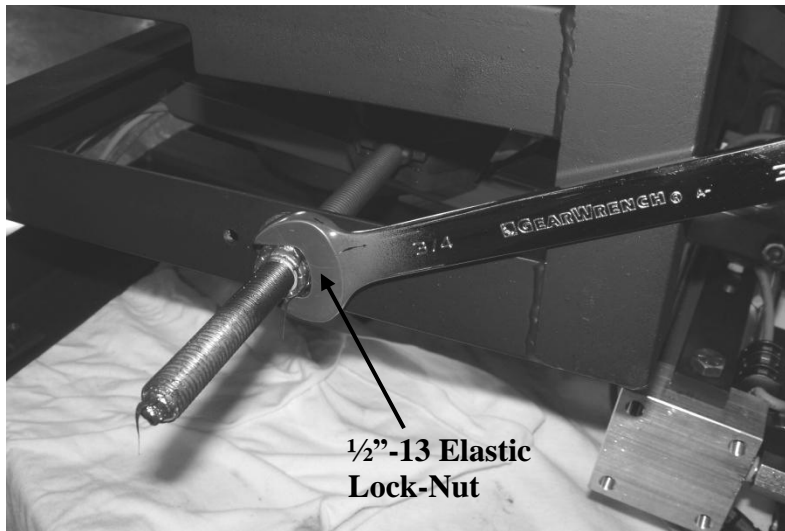

Diagram 57

Adjusting Elastic Lock Nut with 3/4" Wrench

- 12. One can now loosen the set screw (5/32" Hex Wrench) on the clutch rod-end of the Uni-Band. Pull back and down on the rod end to remove it from the clutch. (See Diagram 59).

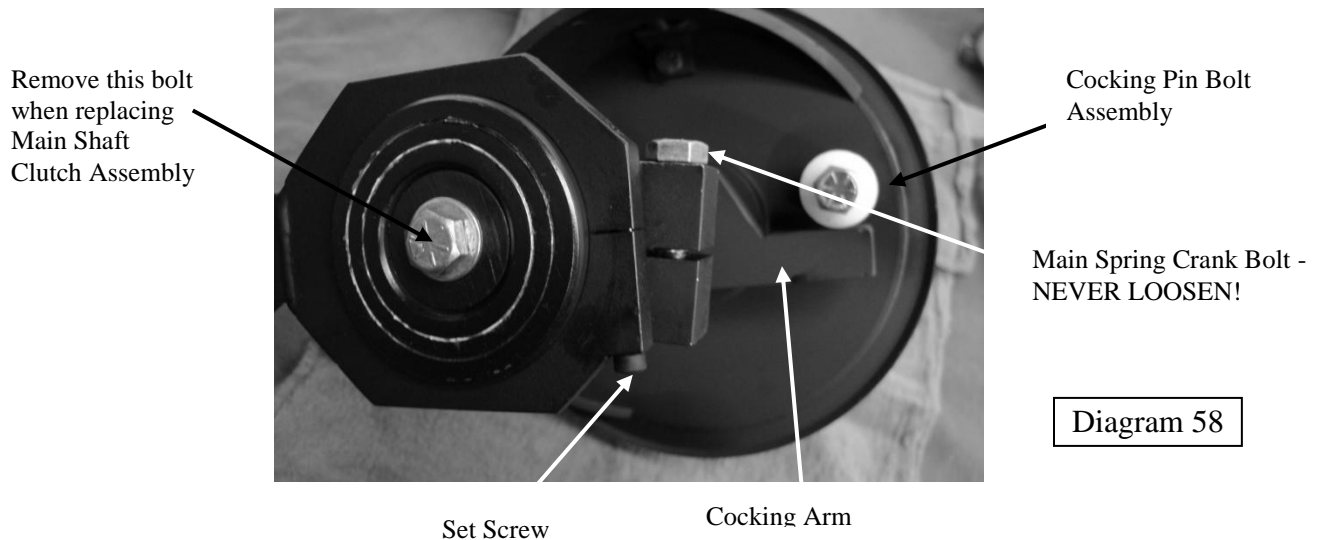

Diagram 58

Main Shaft Clutch Assembly Connection to Throw Arm Crank

- 13. Remove the old main shaft clutch assembly from the machine.
- 14. To reassemble put the threaded rod-end through the hole in the frame, and then pull the rod-end onto the clutch. Refer to Diagram 61 for proper positioning of the clutch within the rod-end (note 1/16" gap). Tighten up the rod-end to the clutch using a 5/32" hex head wrench, while keeping the rod-end level to the clutch.



15. Put the 7/16" washer onto threaded rod-end. Then screw on the elastic lock-nut. Refer to "Setting Distance and Speed" page 19. Regarding spring tension and adjustment of the elastic lock-nut.
16. Remove Vise Grip for the Throw Plate.
17. Once the proper distance and speed have been set, re-attach the crank handle, stand-off collar and the crank handle.
18. Inspect the hydraulic hoses to make sure that the rod-end does not rub against them.

WARNING: Do not work on the hoses when the throw arm is cocked. The throw arm must be released and the machine turned off when performing any work on the Pat-Trap[®].

CHANGING A PAIR OF UNI-BANDS ON A MAIN SHAFT CLUTCH SYSTEM

1. Let off the crank handle tension.
2. Turn the machine on to cock the throw arm.
3. When the throw arm stops at the throw arm brake, turn the machine off without releasing the throw arm.
4. **WHEN THE THROW ARM IS COCKED, BE SURE TO STAND BEHIND THE TRAP AND STAY CLEAR OF THE THROW ARM.** To completely release the tension on the throw arm carefully, manually, release the throw arm by first looping a rope or cord around the end of the throw arm. Then, holding back on the rope at 90 degrees to the throw arm, slowly move the throw arm past the brake and guide it around to the front of the machine.
5. Move the throw arm so that it is 6 7/8" from the right hand corner of the throw plate. See Diagram 53.
6. Clamp a vise-grip onto the throw plate with the throw arm at 6 7/8" to prevent the throw arm from moving forward. See Diagram 54.
7. Do not loosen the throw arm crank bolt. Diagram 43.
8. Changing the Uni-Bands can be done without removing the threaded rod-end from the machine.



9. Remove the Uni-Band connecting bolts. Disconnect the rod-end from the clutch by loosening the rod-end bolt using a 5/32" hex head wrench; pull down on the rod-end to remove it. See Diagrams 60, 61 and 62

10. When re-assembling with the new pair of Uni-Bands, leave the 3/8 –24 x2 1/4" Grade 8 bolts slightly loose at first. Then, pull the rod-end onto the clutch. Refer to Diagram 61 for proper positioning of the clutch within the rod-end (note 1/16" gap). Tighten the rod-end bolt using a 5/32" hex head wrench. Keep the rod-end level on the clutch. Refer to Diagram 60 for right side up.

Align the Uni-Bands as follows: See diagrams 60, 61 and 62

- A. Keep the clamp in front of the throw arm at 6 7/8" (Step 2)
 - B. With the rod-ends and Uni-Bands in alignment to one another, torque the bolts to 10 ft/lbs.
 - C. Tension the Uni-Bands with ten turns of the crank handle.
 - D. Use two 9/16" wrenches. Hold back on the bolt head (on top) while tightening the nut (on bottom)
 - E. Put equal pressure on both of the wrenches and torque the bolts to 35 ft/lbs minimum – 40 ft/lbs maximum. If using the sprocket toothed washers torque to 25 lbs. "Sprocket toothed washer must be used if the area around the holes is not indented."
11. Remove the vise grip from the throw plate.
 12. Refer to the section on *Setting Distance and Speed (page 19)*, regarding minimum spring tension and adjustment of the elastic lock-nut.
 13. Begin normal operation of the machine.



ASSEMBLY/INSTALLATION OF THE UNI-BAND (Main Spring) to the MAIN SHAFT CLUTCH

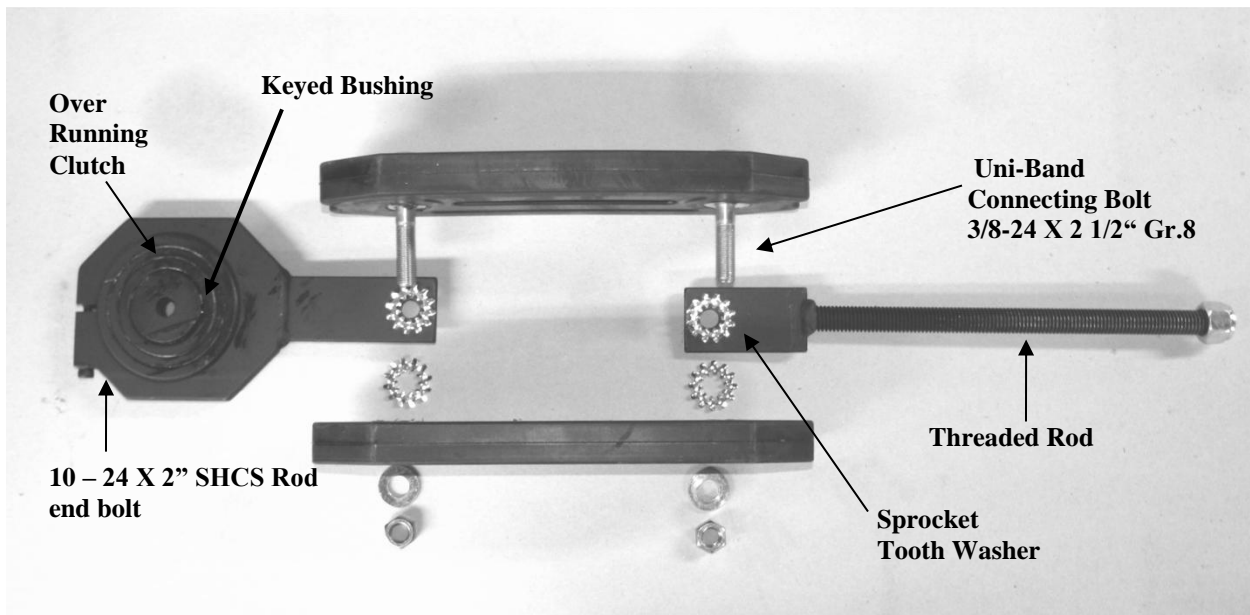
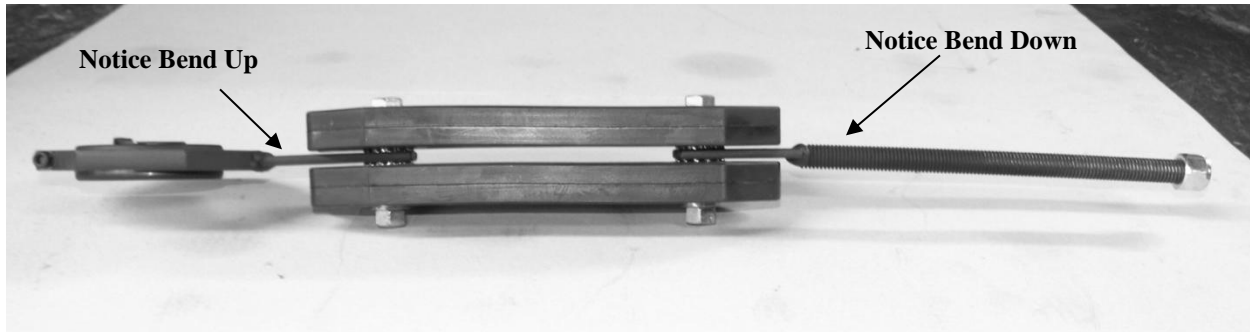

Diagram 60

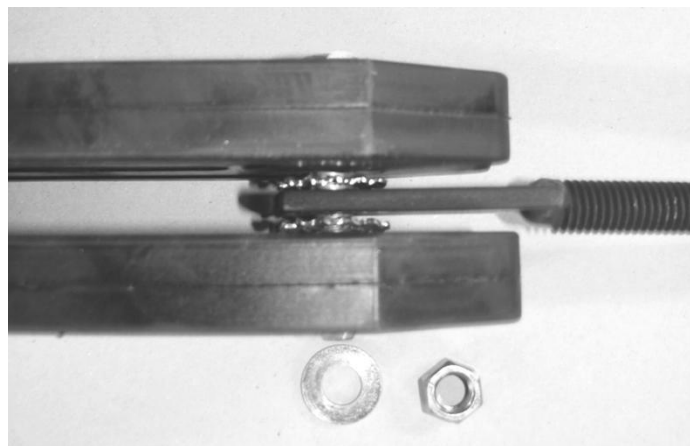
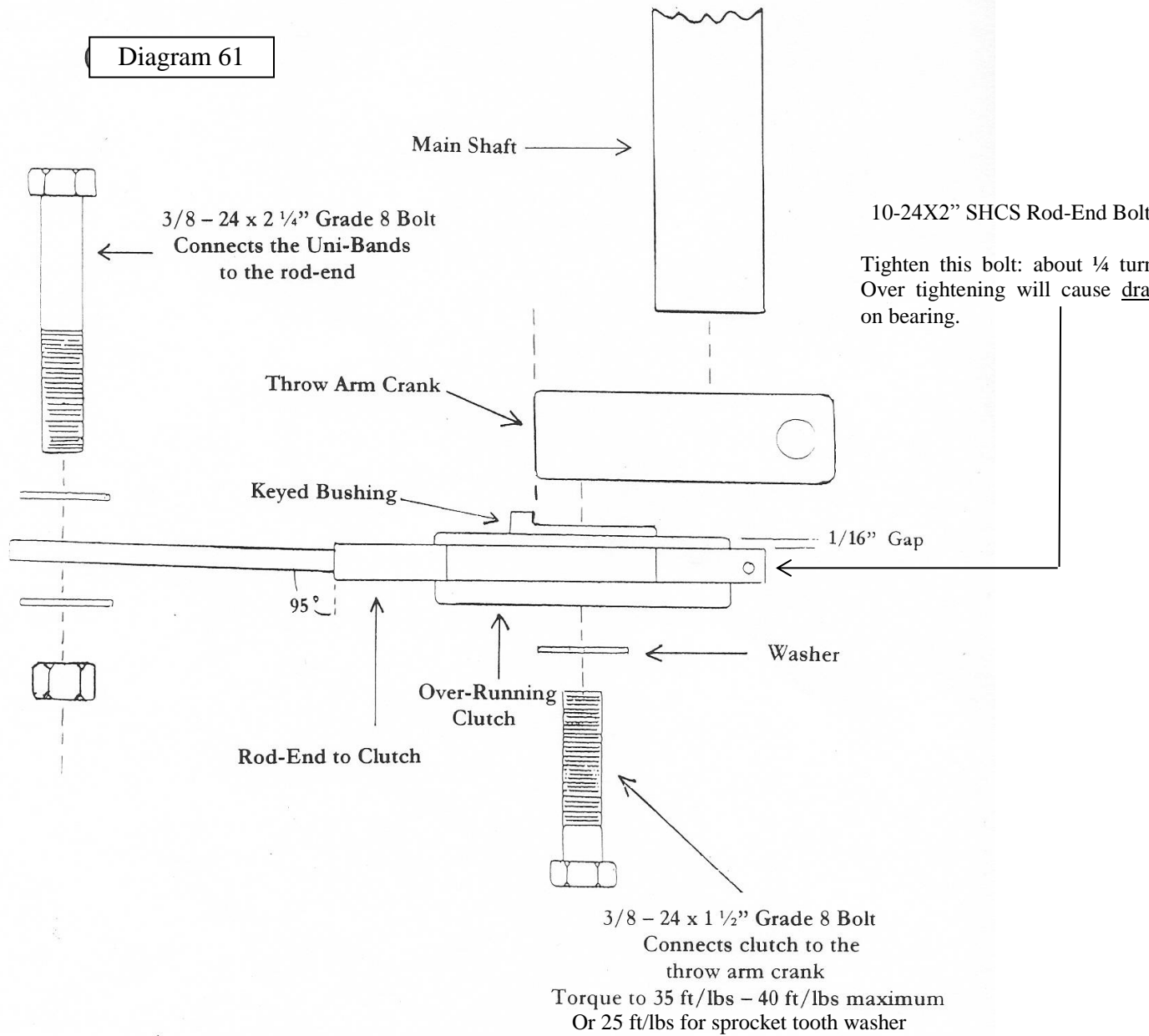
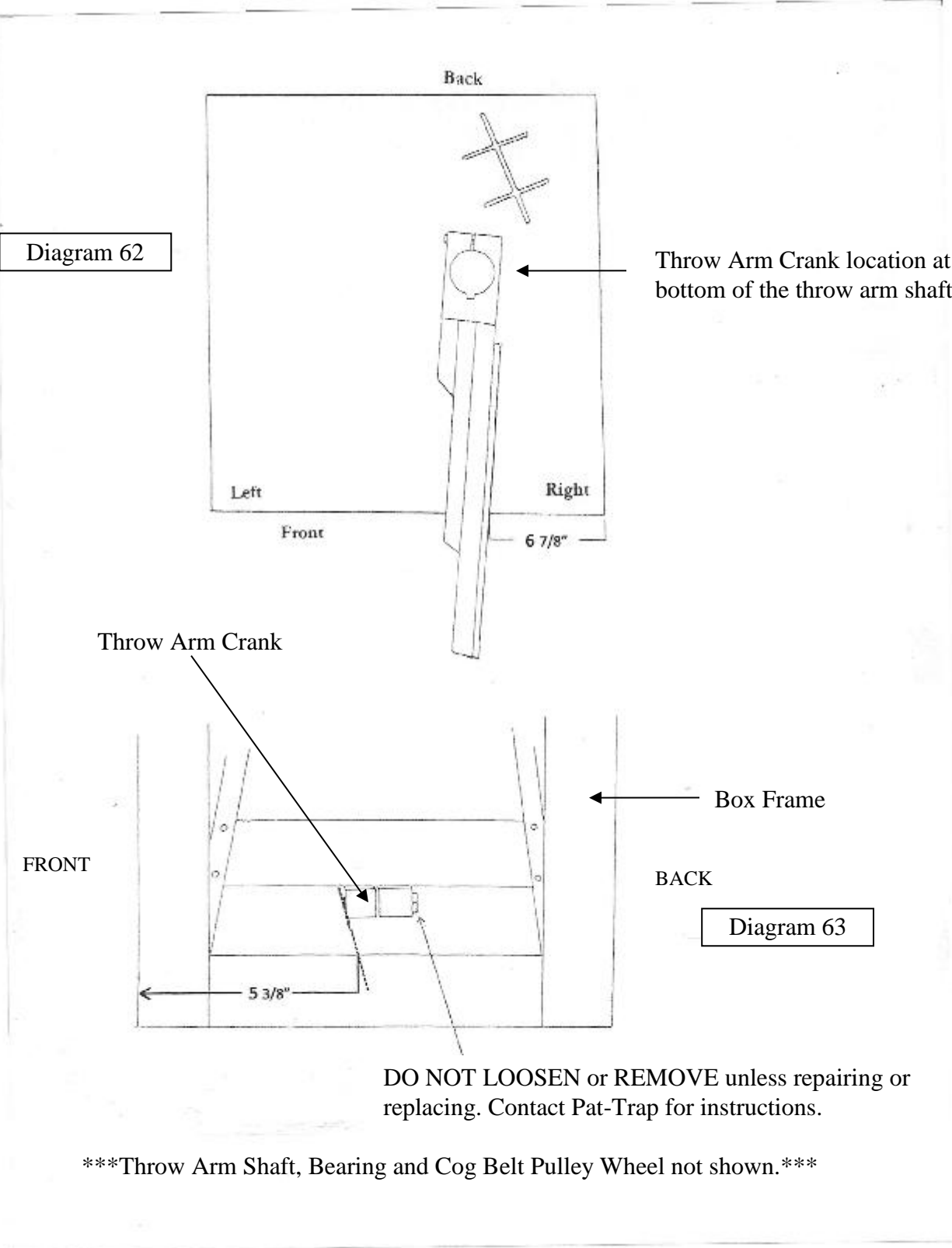



Diagram 61







REPLACEMENT OF THE ELEVATOR EXTENSION SPRING

*****IMPORTANT:** Do not loosen or remove either the lock screw that the bottom of the spring hooks onto or the set screw. The screw is holding the bearing block in position so that the bearing is in alignment with the cam – See Diagram 64.

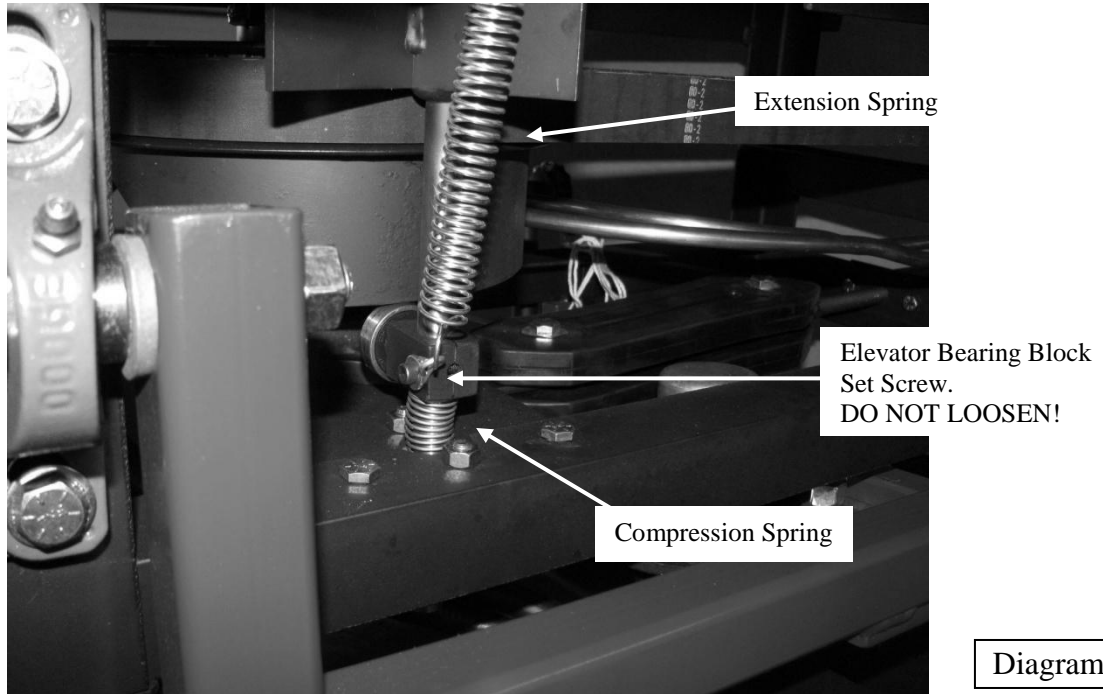

Elevator Bearing Block Detailing Bearing on Cam

1. Turn the machine on.
2. Fire the throw arm and then turn the machine off as soon as the elevator goes up: When the cam leaves the cam bearing.
3. If disconnecting the spring, remove the top end first.
4. If connecting the spring, connect the bottom end first.

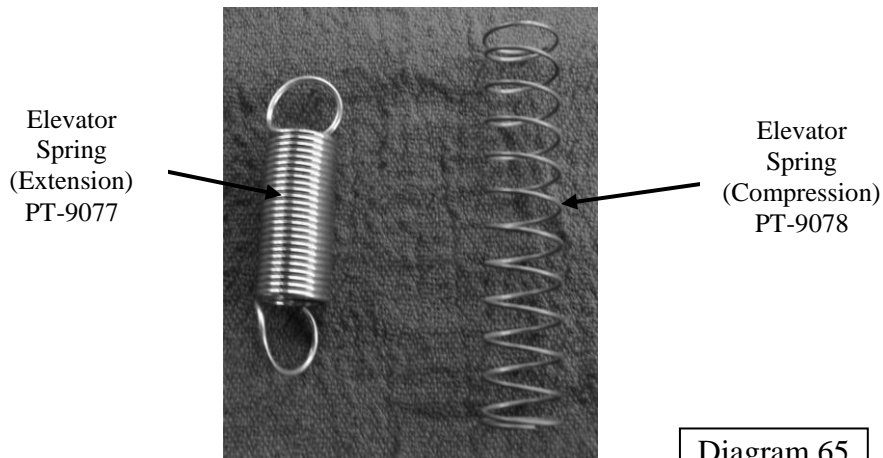



REPLACEMENT OF THE ELEVATOR COMPRESSION SPRING

1. Turn the machine on. As soon as the elevator goes up, turn the machine off.
2. Remove the two elevator rod guide bolts (7/16" wrench). See Diagram 66.

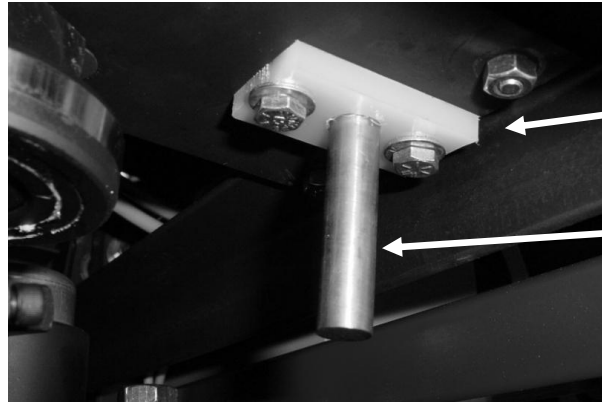

Elevator Rod
Guide plastic

Stainless Steel
Elevator Rod

Diagram 66

Elevator Rod Guide

3. Remove the ELEVATOR ROD GUIDE. The plastic elevator rods guide must be replaced the same way as it was found (i.e., do not flip over).
4. Put the compression spring on over the elevator rod.
5. Replace the Elevator Rod Guide.
6. Fasten the two bolts only slightly snug; over tightening will deform the material and possibly cause the guide to tighten against the elevator rod.



THROW ARM SHAFT BEARING MAINTENANCE

Grease both the Upper and Lower Flange Bearings that Support the Main Shaft (throw arm) and Main Gear Belt Pulley Wheel once a year with a **PREMIUM** grade lubricating grease such as Lithium or Mobil EP1. Heavier-weight grease will “gum-up” and not allow the throw arm shaft to rotate freely. Diagram 67.

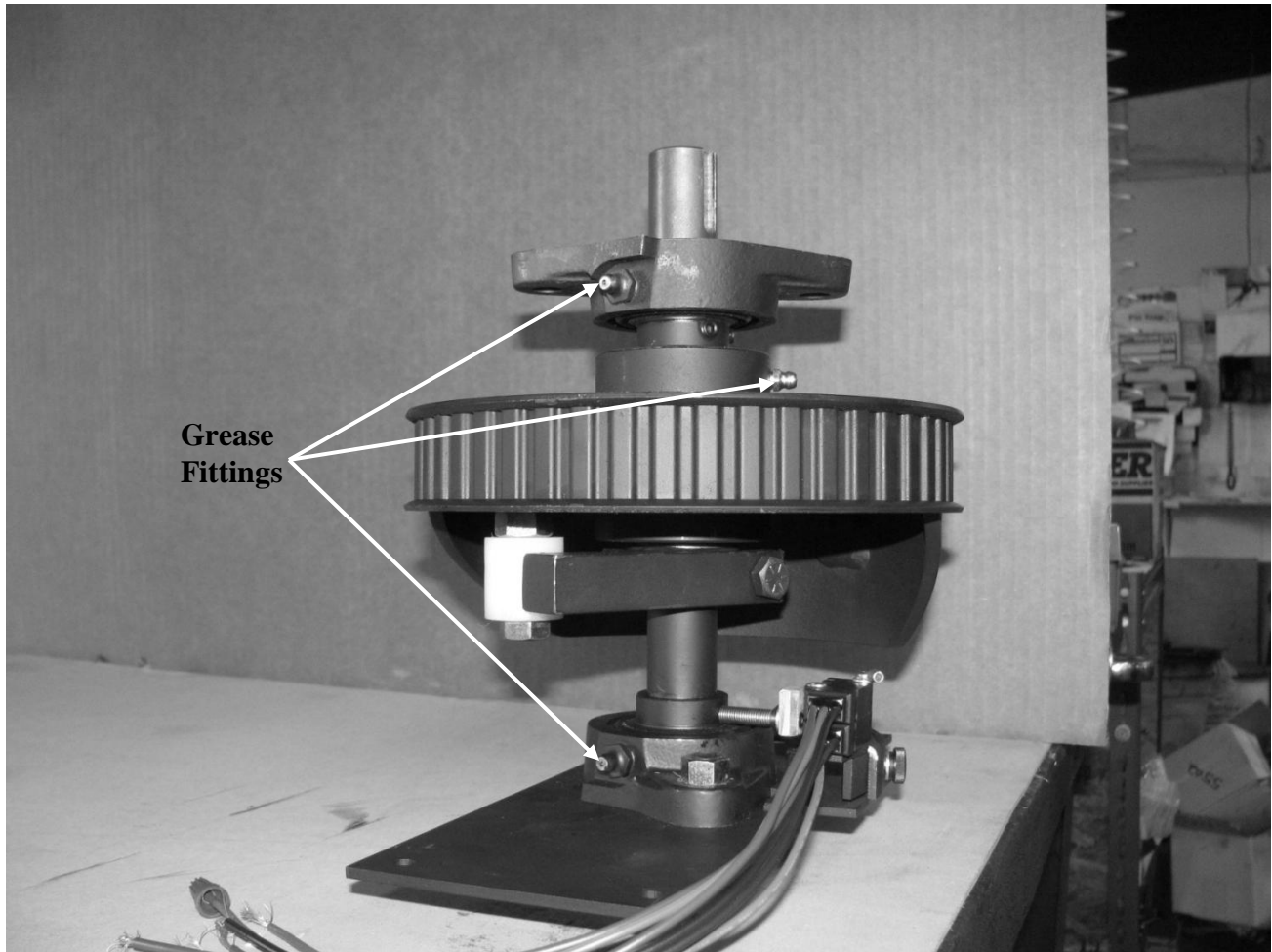

**Grease
Fittings**

Throw Arm Drive Shaft Assembly

Diagram 67



HYDRAULIC VALVE IDENTIFICATION – STANDARD PAT-TRAP[®]

The top valve on a standard PAT-TRAP[®] machine is a “soft shift” valve, and it controls the oscillation hydraulic cylinder. Diagram 68.

The lower valve on a standard PAT-TRAP[®] machine is a “single solenoid” hard shift valve, and it controls the hydraulic motor which cocks the throw arm and advances the turret. It is not a “soft shift” valve.



Hydraulic Valves on Standard PAT-TRAP[®]



HYDRAULIC VALVE IDENTIFICATION – WOBBLE PAT-TRAP®

The top valve on a PAT-TRAP® Wobble machine is a “soft shift” valve, and it controls the horizontal oscillation hydraulic cylinder. Diagram 69

The middle valve on a PAT-TRAP® Wobble machine is a “single solenoid” hard shift valve, and it controls the hydraulic motor which cocks the throw arm and advances the turret. It is not a “soft shift” valve.

The bottom valve on a PAT-TRAP® Wobble machine is a “soft shift” valve, and it controls the vertical “wobble” hydraulic cylinder. Diagram 69.

Single Solenoid Valve
PT-9060
(Throw Arm)

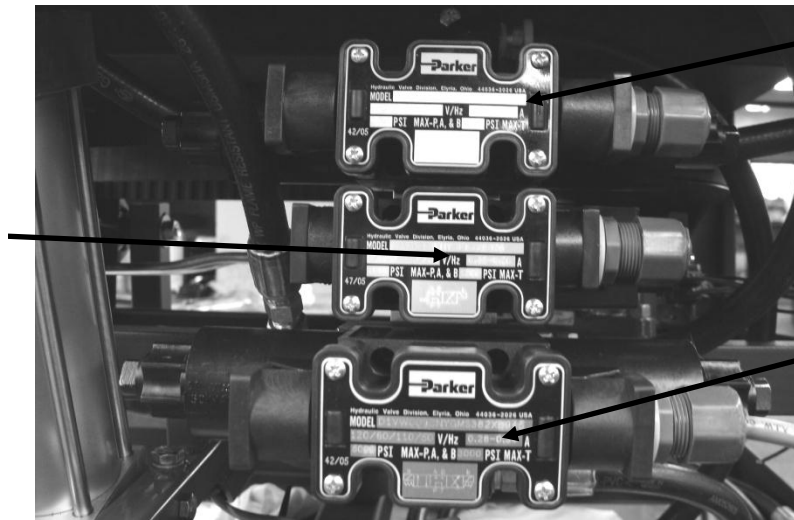

Soft Shift Valve
PT-9061
(Oscillation)

Soft Shift Valve
PT-9061
(Wobble)

Diagram 69

Hydraulic Valves on PAT-TRAP® Wobble

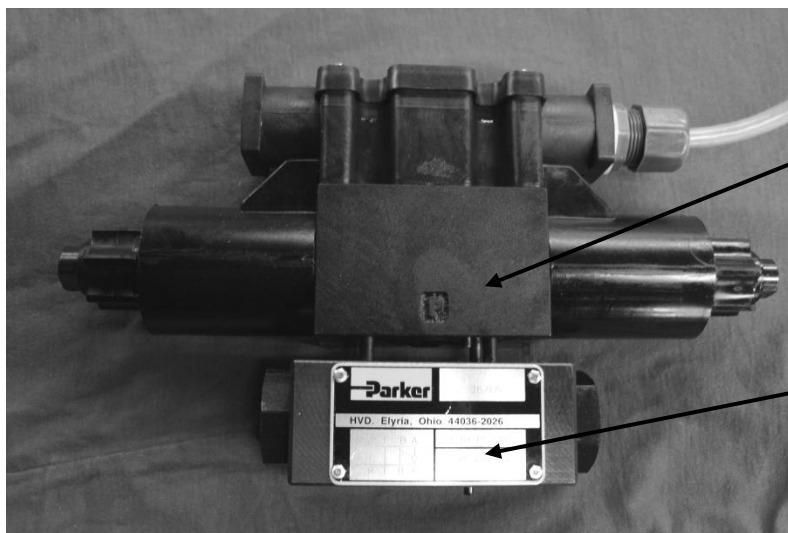

Soft Shift Valve
PT-9061
(Wobble)

Check Valve
Wobble Only
PT-9062

Diagram 70

Wobble Soft Shift Valve shown with Check Valve



SOFT SHIFT VALVE WIRING GUIDE (OSCILLATION/WOBBLE VALVES)

NEVER STAND IN FRONT OF A TRAP MACHINE. THE TRAP MACHINE MUST BE TURNED OFF AND THE SPRING RELEASED BEFORE ENTERING THE TRAP HOUSE. NEVER ATTEMPT TO MAKE ANY ADJUSTMENT WHILE THE THROW ARM IS COCKED.

The wiring guide for the Soft Shift Valve on a PAT-TRAP® is as pictured in Diagram 71 below:

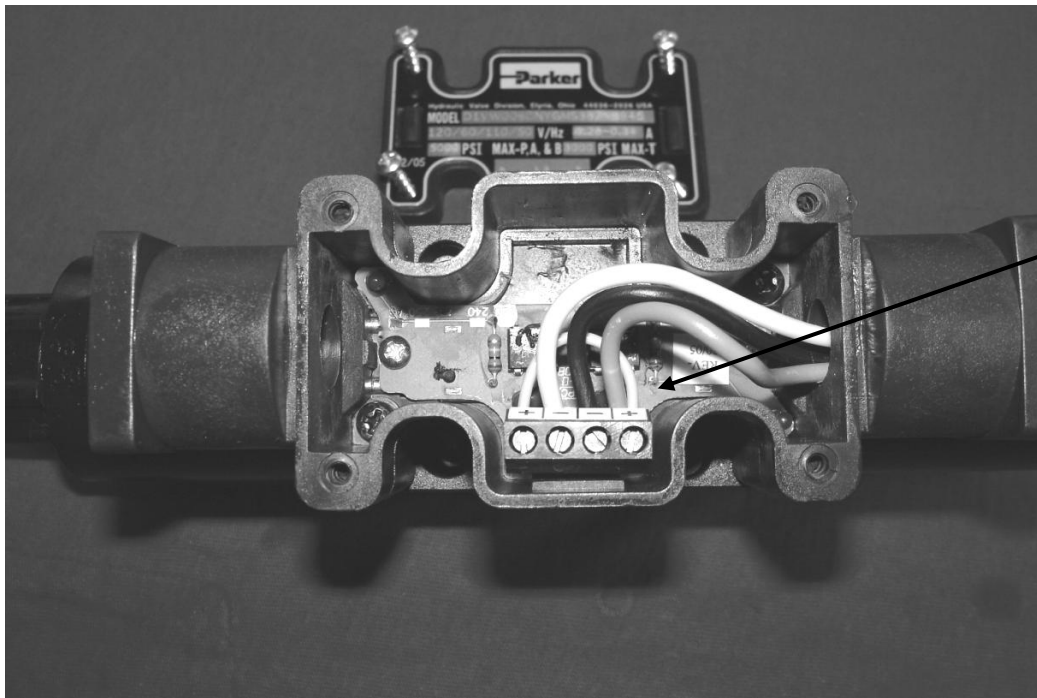

Note: Jumper Wire

Diagram 71

Wiring of Soft Shift Valve

Wiring Terminals from Left to Right:

- Jumper Wire (+)
- White Wire (-)
- Black Wire (-)
- Green Wire and Jumper Wire (+)



SINGLE SOLENOID VALVE (THROW ARM/TURRET) WIRING GUIDE

NEVER STAND IN FRONT OF A TRAP MACHINE. THE TRAP MACHINE MUST BE TURNED OFF AND THE SPRING RELEASED BEFORE ENTERING THE TRAP HOUSE. NEVER ATTEMPT TO MAKE ANY ADJUSTMENT WHILE THE THROW ARM IS COCKED.

The wiring guide for wiring the Single Solenoid Valve on a PAT-TRAP® is as pictured in Diagram 72 below:

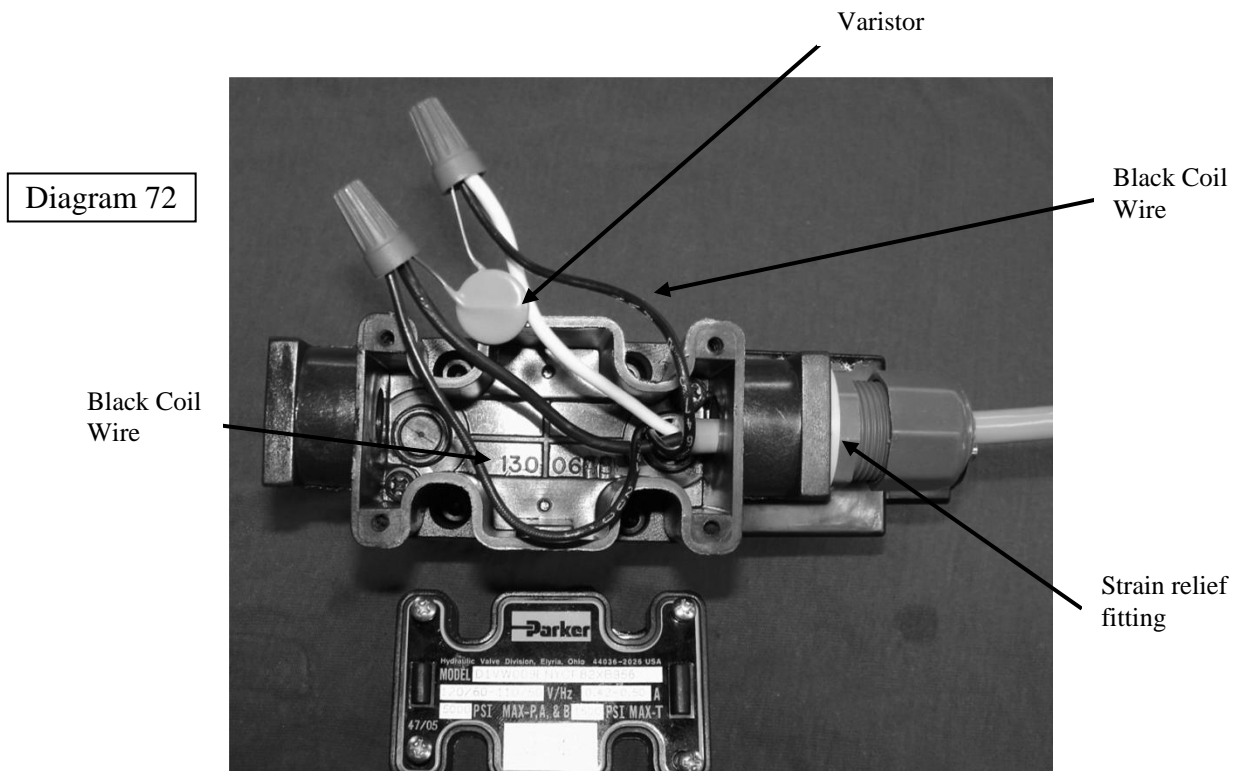

Wiring of Single Solenoid Valve

Connect one of the valve's black coil wires to each of the black and white wires entering the strain relief fitting along with a leg from the Varistor as shown above.



REPLACEMENT OF A HYDRAULIC VALVE

1. NEVER STAND IN FRONT OF A TRAP MACHINE. THE TRAP MACHINE MUST BE TURNED OFF AND THE SPRING RELEASED BEFORE ENTERING THE TRAP HOUSE. NEVER ATTEMPT TO MAKE ANY ADJUSTMENT WHILE THE THROW ARM IS COCKED.
2. Disconnect the PAT-TRAP® from its power source.
3. Remove the cover plate on the valve's terminal box as shown in Diagram's 71 & 72.
4. Disconnect the electrical wires that are located within the valve's terminal box and remove from the strain relief fitting located on the side of the valve.
5. Place a paper towel or rag below the valve to be removed.
6. Remove the old hydraulic valve from the hydraulic sub-plate manifold by removing the four bolts that hold it in place. A 5/32" T-Handled Hex Wrench works best as shown in Diagram 73. Make sure that the holes are cleaned out before using the wrench.



Diagram 73

Loosening/Tightening Valve Mounting Screws

7. Replace the old valve with the proper replacement valve, and secure to the hydraulic sub-plate manifold with the four bolts that hold it in place. A 5/32" T-Handled Hex Wrench works best as shown in Diagram 73.
8. Note: Use caution that the four O-Rings located around the valve's orifice ports are securely in place or else a leak will occur. See Diagram 74.

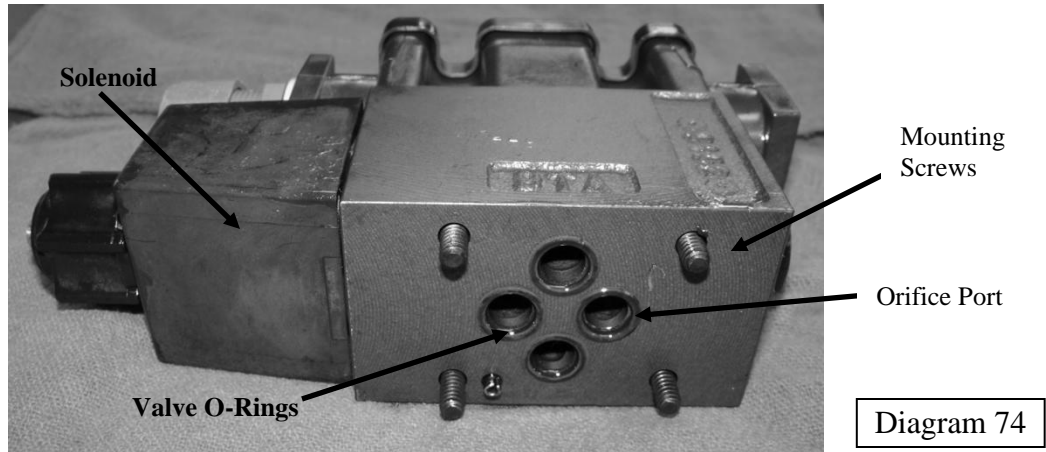

Rear View of Single Solenoid Valve

9. Re-attach the wires that are located within the valve’s terminal box after feeding them through the strain relief fitting located on the side of the valve. Refer to Diagram 71 or 72 for the proper valve wiring guide.
10. Re-attach the cover plate on the Valve’s Terminal Box as shown in Diagram’s 71 or 72.
11. Connect the PAT-TRAP® back to its power source and resume operation.

WIRING GUIDE FOR FIELD ANGLE LIMIT SWITCHES (#11 and #12)

Diagram 75



PAT-TRAP® Oscillation Cylinder with Field Angle Switches and 2-Hole Spacer Bar



To replace a FIELD ANGLE LIMIT SWITCH use the following directions:

1. NEVER STAND IN FRONT OF A TRAP MACHINE. THE TRAP MACHINE MUST BE TURNED OFF AND THE SPRING RELEASED BEFORE ENTERING THE TRAP HOUSE. NEVER ATTEMPT TO MAKE ANY ADJUSTMENT WHILE THE THROW ARM IS COCKED.
2. Disconnect the PAT-TRAP[®] from its power source.
3. Open the cover of the Electrical Enclosure located on the back of the PAT-TRAP[®]. Use a string to keep the cover up while accessing the enclosure.
4. Loosen the screws on the Romex Connector located on the rear exterior of the electrical enclosure. Remove the switch wires from the relay base. Tie a string to the switch wire ends and pull out of the box. Fish the new switch wire back into the box.
5. The connections for the field limit switches to the #2 Relay (8-Pin) shown in Diagram 76 are as follows:

CONNECTIONS TO THE #2 RELAY BASE (for latching relay)

SWITCH # 11 (NO):
Red wire to pin #1
Black wire to pin #10

SWITCH # 12 (NO):
Red wire to pin # 1
Black wire to pin # 6

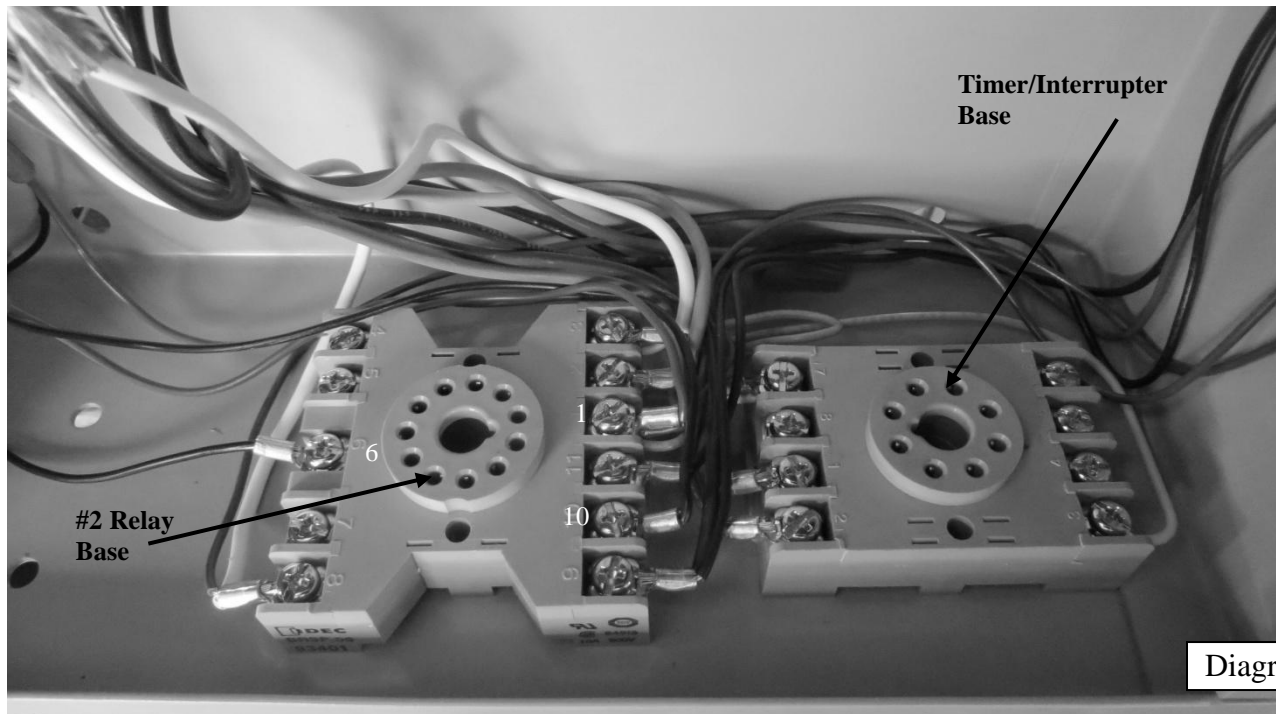

Diagram 76

Inside the Electrical Enclosure of the Standard PAT-TRAP[®]

6. After replacing the appropriate field limit switch, close and secure the rear cover of the electrical enclosure. Connect the PAT-TRAP[®] back to its power source and resume operation.



WOBBLE WIRING GUIDE FOR UP and DOWN LIMIT SWITCHES (#11A and #12A)

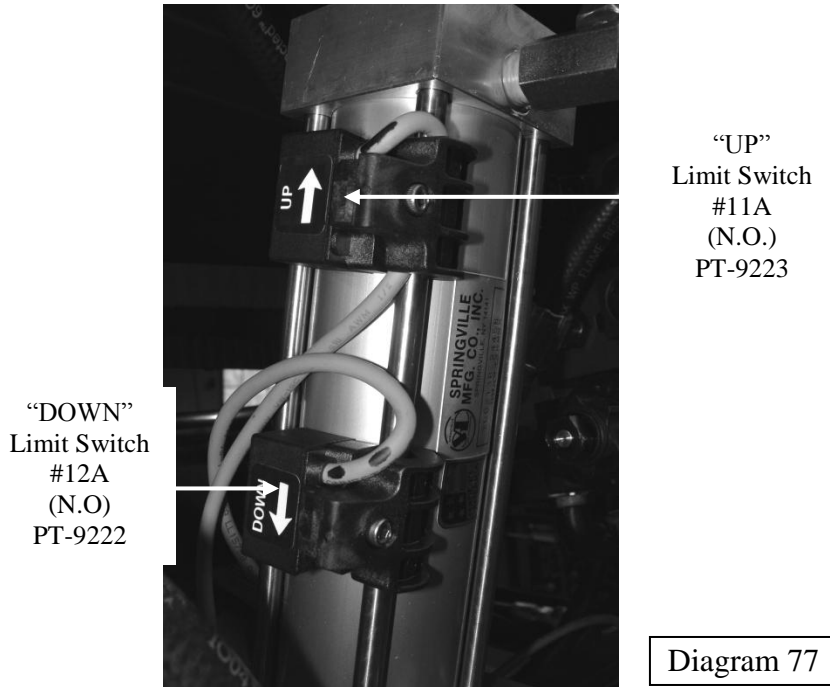

Limit Switches on the PAT-TRAP® Wobble Hydraulic Cylinder

To replace a Wobble Up or Down LIMIT SWITCH use the following directions:

NEVER STAND IN FRONT OF A TRAP MACHINE. THE TRAP MACHINE MUST BE TURNED OFF AND THE SPRING RELEASED BEFORE ENTERING THE TRAP HOUSE. NEVER ATTEMPT TO MAKE ANY ADJUSTMENT WHILE THE THROW ARM IS COCKED.

1. Disconnect the PAT-TRAP® from its power source.
2. Open the cover of the Electrical Enclosure located on the back of the PAT-TRAP®. Use a string to keep the cover up while accessing the enclosure.
3. Loosen the screws on the Romex Connector located on the rear exterior of the electrical enclosure. Remove the switch wires from the relay base. Tie a string to the switch wire ends and pull out of the box. Fish the new switch wire back into the box.
4. The connections for the Wobble Up or Down limit switches in (Diagram 81) to the #3 Relay (8-Pin) shown are as follows:

CONNECTIONS TO THE #3 RELAY BASE

SWITCH # 11A (NO):
 Red wire to pin #1
 Black wire to pin #10

SWITCH # 12A (NO):
 Red wire to pin #1
 Black wire to pin #6

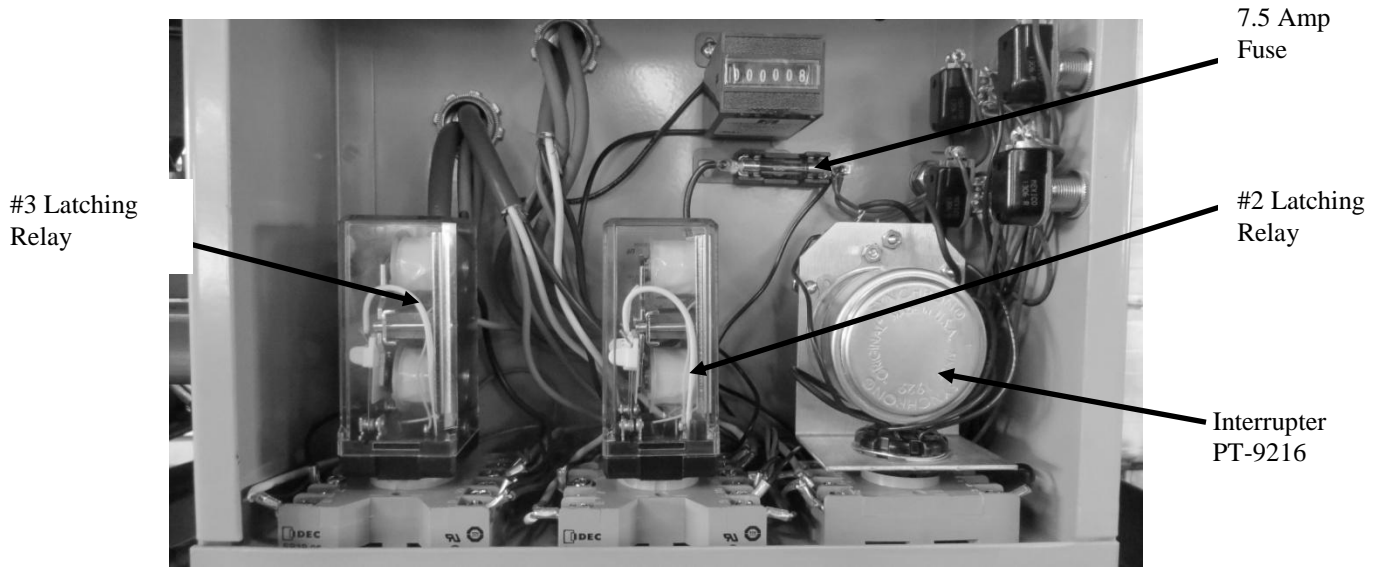

Inside the Electrical Enclosure of the PAT-TRAP® Wobble

Diagram 78

5. After replacing the appropriate Up or Down Wobble limit switch, close and secure the rear cover of the electrical enclosure. Connect the PAT-TRAP® back to its power source and resume operation.

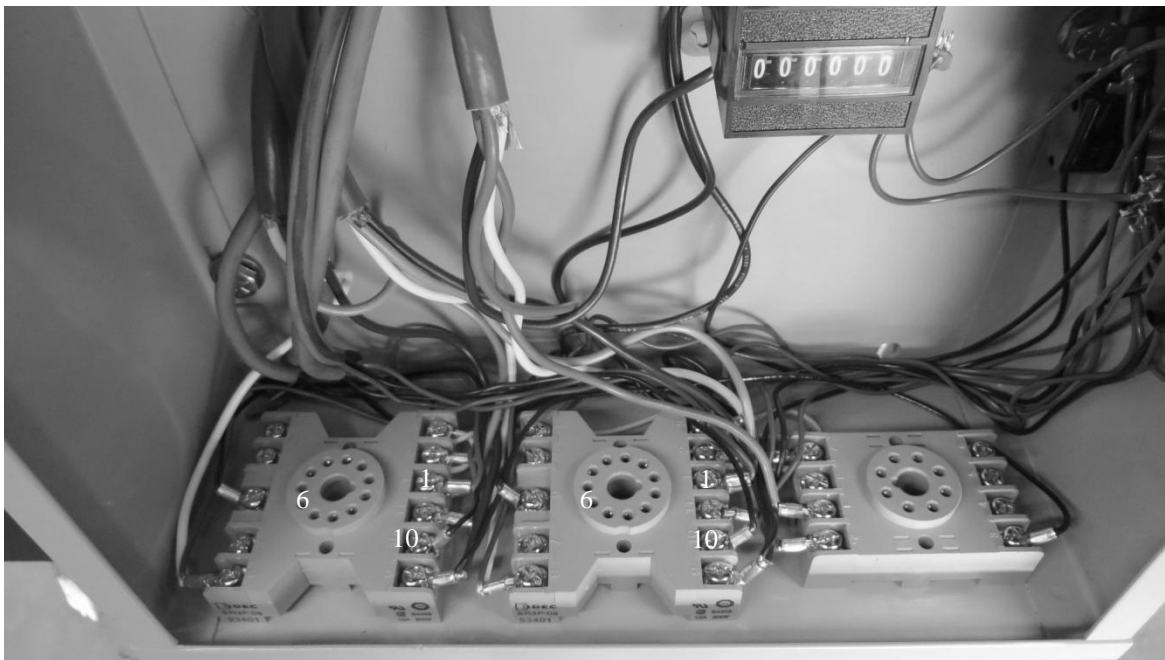



REPLACEMENT OF OSCILLATION CYLINDER

To replace a horizontal hydraulic oscillation cylinder use the following directions:

NEVER STAND IN FRONT OF A TRAP MACHINE. THE TRAP MACHINE MUST BE TURNED OFF AND THE SPRING RELEASED BEFORE ENTERING THE TRAP HOUSE. NEVER ATTEMPT TO MAKE ANY ADJUSTMENT WHILE THE THROW ARM IS COCKED.

1. Disconnect the PAT-TRAP[®] from its power source.
2. Tools required: 9/16" wrench (ratchet or speedy wrench will help), 9/64" hex wrench, 1/2" wrench, 5/8" and 11/16" wrenches (or adjustable wrench).
3. Remove field angle limit switches from the cylinder tie rods with a 9/64" hex wrench.
4. Loosen the two cylinder bar bolts, but do not remove yet, with a 9/16" wrench. The Cylinder Bar remains on the machine.

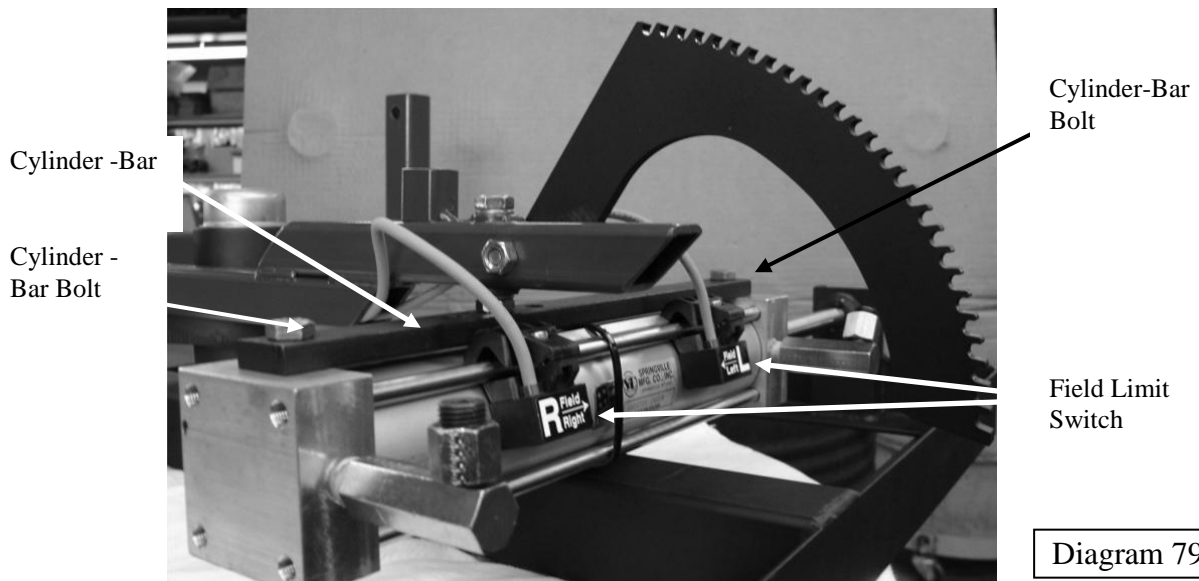

Removing Cylinder Bar Bolts

5. Remove the cylinder rod-end bolt using a 1/2" open-end wrench on the milled Wrench flat at the end of the cylinder rod and a 9/16" wrench on the rod-end bolt. (Do not lose the bushings or bushing caps.) See Diagram 80.

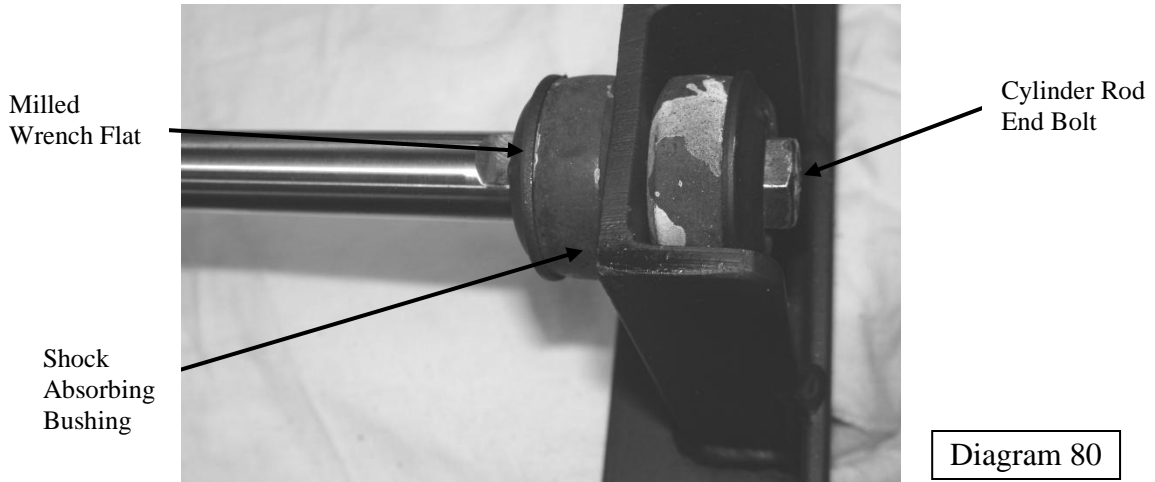

Removing Shaft Rod- End Bolt From Frame

6. Remove the cylinder bar bolts.
7. Now that the cylinder is free, remove the hydraulic hoses that connect to the long adapters. Use the 5/8” and 11/16” open-end wrenches to perform this task.
8. When putting on the new oscillation cylinder, first secure the cylinder to the cylinder bar with the two bolts.
9. Tighten the rod-end bolt to the cylinder rod, making sure that the bushings and bushing caps are in place.
10. Make sure that the cylinder bar bolts are tight.
11. Replace the field angle limit switch to the cylinder tie rods with the 9/64” hex wrench. Do not over tighten the plastic switch bracket clamp because it **WILL** break.
12. Connect the hoses. When tightening, make sure that the hoses are turned slightly away from the frame of the machine. This is done so that the hoses won’t rub against the machine when at the extreme left and right angle limits.
13. After installing the new cylinder, turn on the machine.
14. Put the Auto/Manual switch into the manual position. Push the left button and run the cylinder to the end.
15. Push the right button and run the cylinder to the end. Now the air is out of the cylinder.
16. Check the oil level within the hydraulic pump reservoir and add **5W-20 oil** as required.
17. Move the cylinder back to center and begin normal operation.



REPLACEMENT OF WOBBLE CYLINDER

To replace a vertical hydraulic Wobble cylinder use the following directions:

1. Tools required: 1" thick block of wood, 9/16" wrench (ratchet or speedy wrench will help), 9/64" hex wrench, 1/2" wrench, 5/8" and 11/16" wrenches (or adjustable wrench).
2. Set the 1" thick block of wood on the frame post. See Diagram 81.
3. Carefully lower the machine onto the block of wood without crushing it.

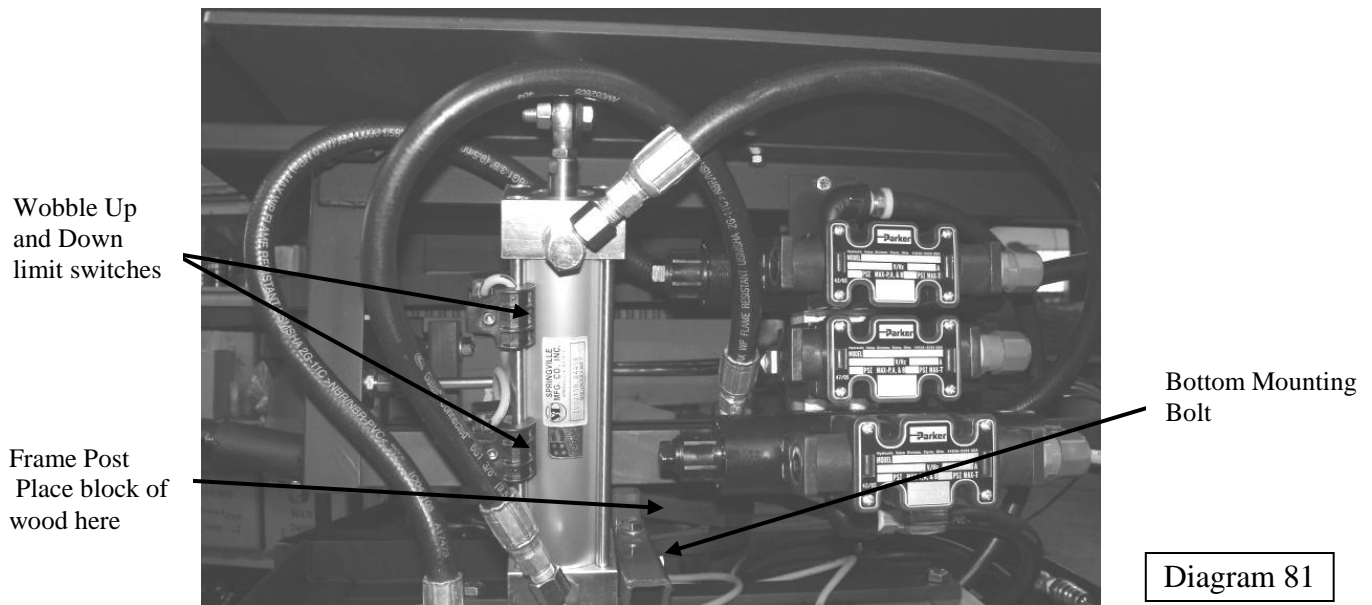

Wobble Cylinder

4. STAND BEHIND THE PAT-TRAP[®] MACHINE RELEASE THE THROW ARM AND TURN OFF THE MACHINE. THE TRAP MACHINE MUST BE TURNED OFF AND THE SPRING RELEASED BEFORE ENTERING THE TRAP HOUSE. NEVER ATTEMPT TO MAKE ANY ADJUSTMENT WHEN THE THROW ARM IS COCKED.
5. Disconnect the PAT-TRAP[®] from its power source.
6. Remove Wobble Up and Down limit switches from the cylinder tie rods with a 9/64" hex wrench. See Diagram 81.
7. Remove the cylinder rod-end mounting bolt using two 9/16" open-end wrenches. See Diagram 82.

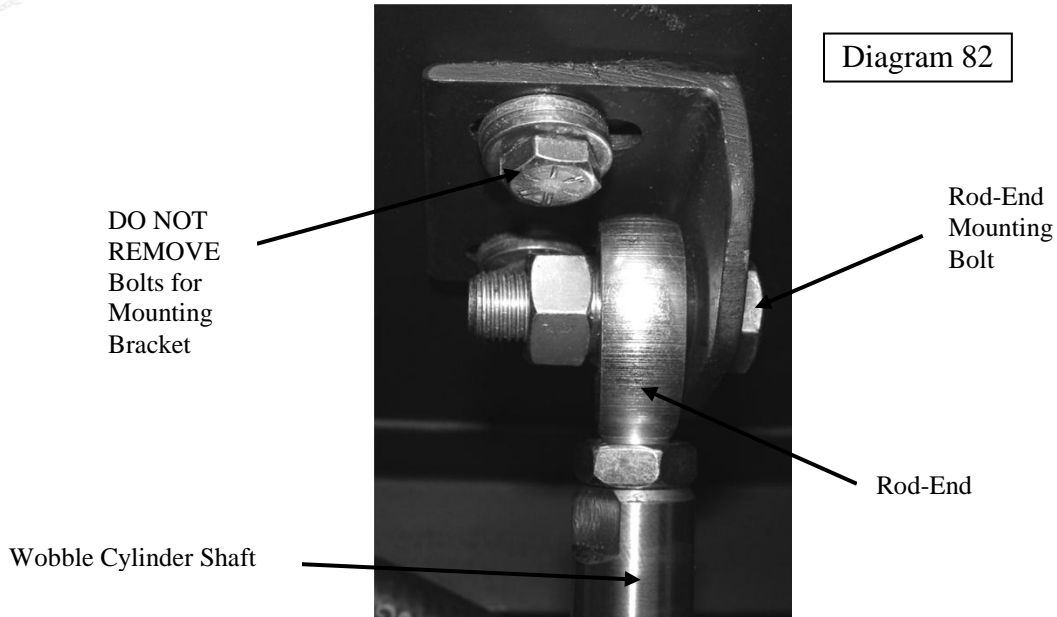

Rod End to Mount Wobble Cylinder to PAT-TRAP®

8. Remove the hydraulic hoses that connect to the short adapters. Use the 5/8” and 11/16” open-end wrenches to perform this task.
9. Remove the bottom mounting bolt located on the bottom of the Wobble Cylinder using a 1/2” wrench. See Diagram 81.
10. When putting on the new Wobble cylinder, first apply a small quantity of Loctite 680 to the last threads of the #5/16-18 x 1-3/4” bottom mounting bolt as shown in Diagram 82.

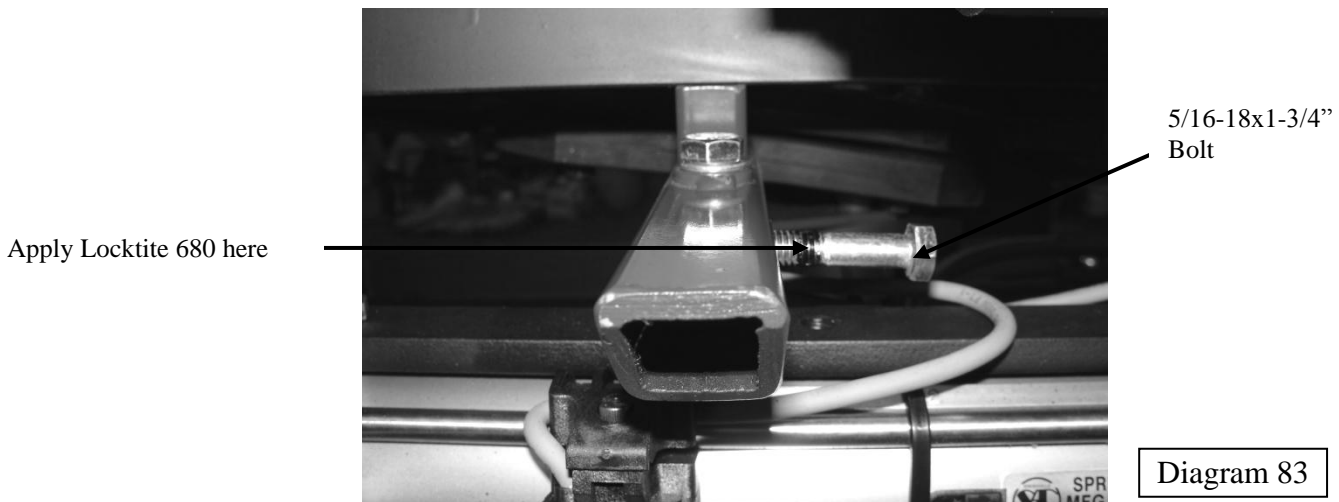

Bolt for to Mount Wobble Cylinder



11. Replace the cylinder rod-end mounting bolt using two 9/16" open-end wrenches. Diagram 82.
12. Remove 1" thick block of wood from frame post.
13. Make sure that the cylinder rod-end mounting bolt is tight (torque to 25-30 ft-lbs).
14. Replace the field angle limit switch to the Wobble cylinder tie rods with the 9/64" hex wrench. Do not over-tighten the plastic switch bracket clamp because it WILL break.
15. Connect the hoses. When tightening, make sure that the hoses are positioned as shown in Diagram 81. This is done so that the hoses won't rub against the machine when at the extreme up, down, left, and right angle limits.
16. After installing the new Wobble cylinder, turn on the machine.
17. Put the Auto/Manual switch into the manual position. Push the UP button and run the cylinder rod to the end. Remove the wooden block.
18. Push the DOWN button and run the cylinder rod to the end. Now the air is out of the cylinder.
19. Check the oil level within the hydraulic pump reservoir and add 5W-20 oil as required.
20. Move the Wobble cylinder back to center (between limit switches) and begin normal operation.



PAT-TRAP, Inc.

Choice of the ATA

632 Western Avenue • Henniker, New Hampshire 03242 • Tel. (603) 428-3396 • Fax (603) 428-7340

Standard Trap Wiring Diagram (with Latching Relay)

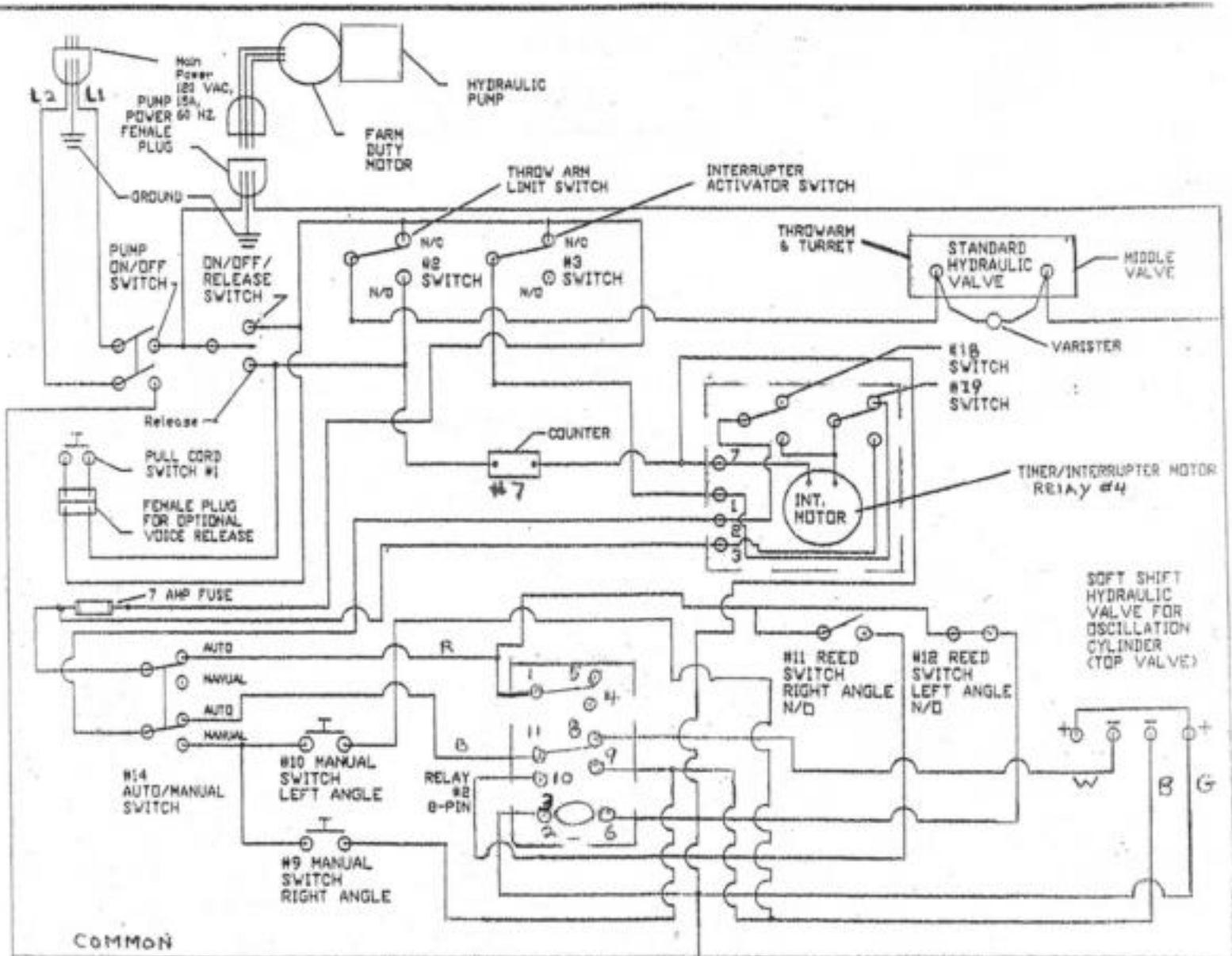



PAT-TRAP, Inc.

Choice of the ATA

632 Western Avenue • Henniker, New Hampshire 03242 • Tel. (603) 428-3396 • Fax (603) 428-7340

Wobble Wiring Diagram (Latching Relay)

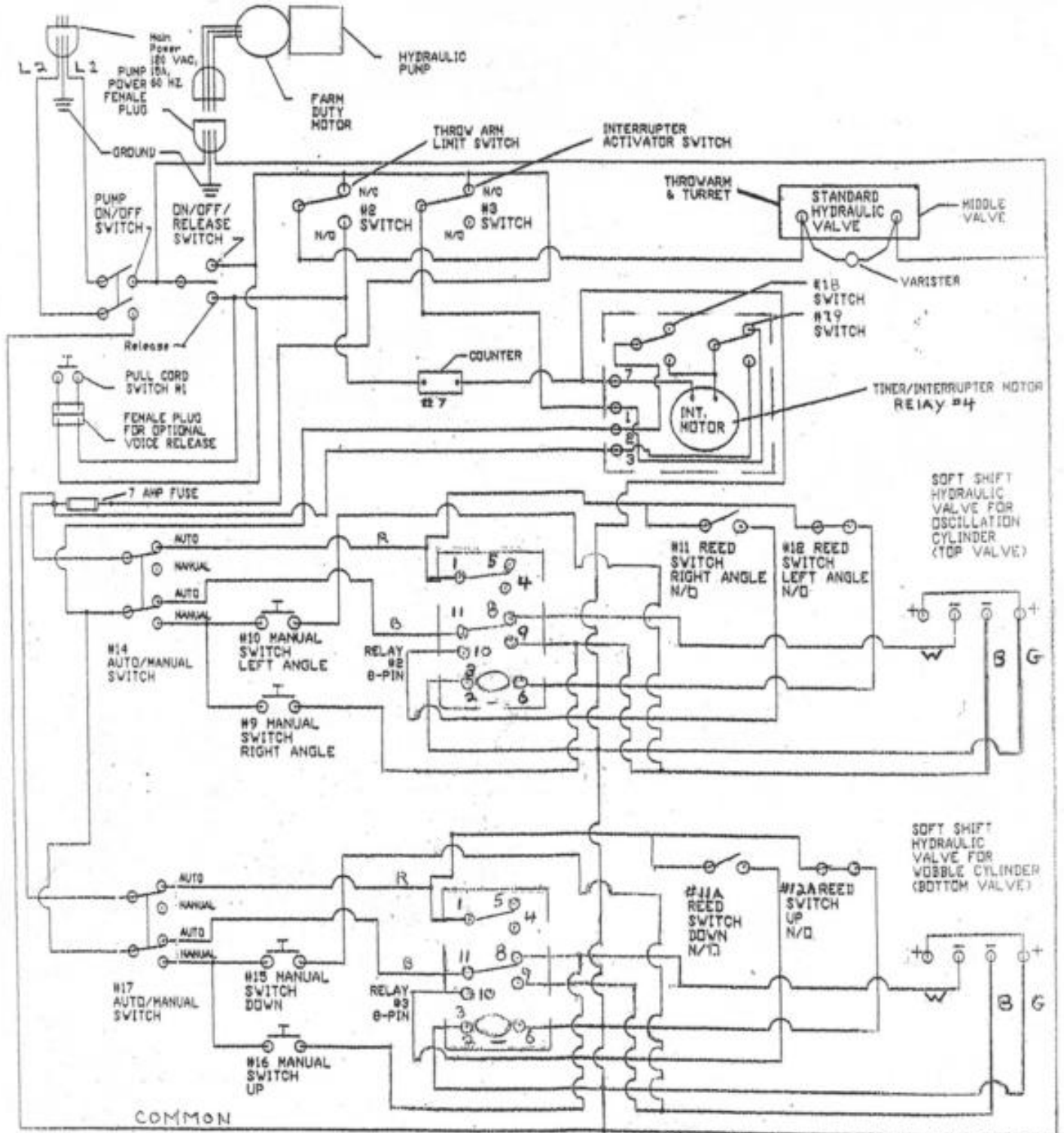



General Maintenance

IMPORTANT: NEVER STAND IN FRONT OF A TRAP MACHINE. THE TRAP MACHINE MUST BE TURNED OFF AND THE SPRING RELEASED BEFORE ENTERING THE TRAP HOUSE. NEVER ATTEMPT TO MAKE ANY ADJUSTMENT WHEN THE THROW ARM IS COCKED.

Surface Mounted Oil Roller Plates need to be oiled every 2-3 weeks, depending on usage: (The Elevated Roller Plate design does not need this maintenance)

Use 3 in 1 oil, or another good quality lubricant. Place a few drops along the edges of the plate so that the oil works its way under the plate.

1. Inspect the o-rings on the target rollers for wear every 6 - 12 months.
2. Inspect the Target brush for wear every 6 - 12 months.
3. Inspect the Throw Arm Brake Rubber and Flat Spring for wear or breakage every 6 - 12 months.
4. Inspect the throw arm approximately every 6 – 12 months.

If a groove forms on the face of the throw arm rubber, or the bottom edge is badly rounded, then the throw arm may be too high on the rim of the target.

To inspect the height of the throw arm you need to disconnect the main spring. First, move the arm to the front of the machine where the target leaves the machine. There should be 1/32" – 1/16" gap between the lip of the target and the bottom of the throw arm rubber. Take the measurement at the end of the throw arm.

After setting the arm to the correct height make sure that the throw arm scrapers clear the throw plate 360 degrees. Also check the clearance between the scraper and the doubles finger. If the throw arm is bent or the rubber is badly worn, send to PAT-TRAP, Inc. to be repaired.

5. Grease the throw arm shaft bearings every 1 ½ - 2 years. (see page 50 in manual)
6. If the Throw arm rubber surface appears glazed use a block of wood and 80 grit sandpaper to re-dress the surface – making sure to keep the sanding block square to the surface.
7. Grease Main Spring Crank Handle threads & washer yearly.



Maintenance Schedule

Item	Part Number	100,000 Targets	200,000 Targets	400,000 Targets	600,000 Targets	800,000 Targets	1,000,000 Targets
Target Brush	9041	•	•	•	•	•	•
O-Rings	9104	•	•	•	•	•	•
Main Spring (Uni-Bands)	9032		•	•	•	•	•
Throw Arm Rubber	SP120		•	•	•	•	•
Grease Main Shaft Bearings			•	•	•	•	•
8-Pin Relay	9208				•		
5W-20 Oil In Pump							•

- - Inspect and/or Replace if worn or a performance issue.



Drying Out a Pat-Trap® Machine After a Flood

1. **DO NOT TURN THE PAT-TRAP® MACHINE ON!** If you have turned the Pat-Trap® machine on before performing these steps you will need to buy a filter system from Pat-Trap, Inc. to remove water from the Pat-Trap® machine.
2. Disconnect the power to the trap house and the Pat-Trap® machine.
3. Open the gray electrical box located on the rear of the Pat-Trap® machine and remove the relays and the timer/interrupter from their respective bases.
4. Using a hair dryer, on a cool setting, dry out the relay bases and the inside of the electrical enclosure.
5. Remove the clear covers on relays and let the relays dry out.
6. Remove the rear cover on the clock motor of the timer/interrupter and let it dry out.
7. Pour out all of the oil in the reservoir of the hydraulic pump.
8. Pull out the drain plugs on the bottom of the farm duty electric motor attached to the hydraulic pump and let dry.
9. Remove all targets from the Pat-Trap® machine.
10. Use compressed air and towels to remove any excess dirt, debris and water on the exterior of the Pat-Trap® machine.
11. When dry, replace the covers on the relays and put them back into their appropriate relay bases.
12. When dry replace the rear cover on the timer/interrupter and replace into the relay base. (Far right location inside the electrical enclosure)
13. When dry replace the drain plugs in electric motor.
14. Replace the oil in hydraulic pump reservoir with new 5W-20 motor oil to the appropriate full level. (2 $\frac{3}{4}$ quarts). Install water filter assembly.
15. Turn on the motor of the hydraulic pump on the Pat-Trap® machine and let it warm up for ten minutes (or longer if it is cold).
16. Turn on the Pat-Trap® machine and check to see that is it working. If problems occur call Pat-Trap, Inc. (603)428-3396.



ASSEMBLY OF THE PINION AND SPROCKET

IMPORTANT: NEVER STAND IN FRONT OF A TRAP MACHINE. THE TRAP MACHINE MUST BE TURNED OFF AND THE SPRING RELEASED BEFORE ENTERING THE TRAP HOUSE. NEVER ATTEMPT TO MAKE ANY ADJUSTMENT WHEN THE THROW ARM IS COCKED.

The sprocket must be tightened onto the pinion shaft to a torque of 120 ft. lbs. To do this you will have to connect the chain to the sprocket, to hold the sprocket stationary, and use a bar to tighten the pinion clockwise. See Diagram.

After tightening the pinion, disconnect the chain and follow the directions for timing of the pinion.

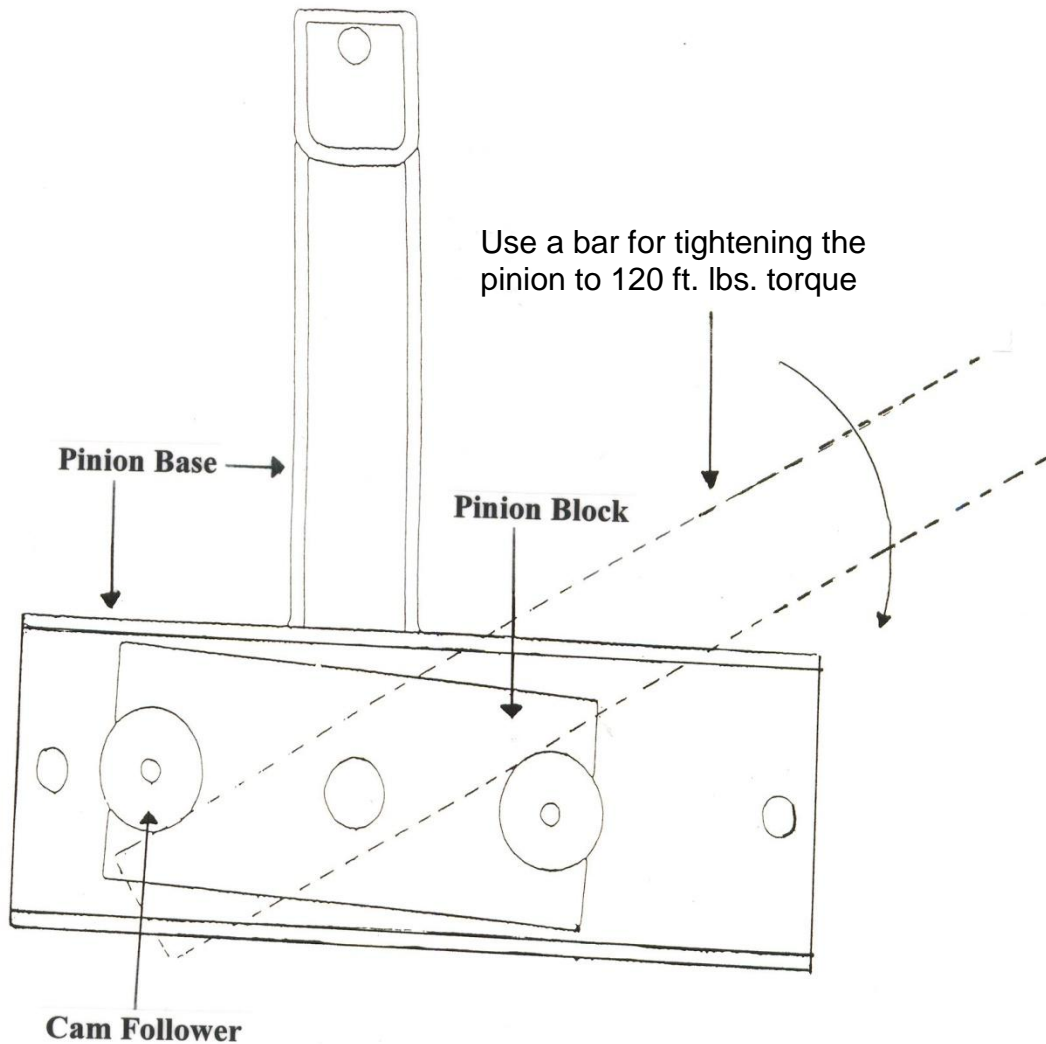



Timing of Pinion – PAT TRAP®

WARNING: NEVER STAND IN FRONT OF TRAP MACHINE. THE TRAP MACHINE MUST BE TURNED OFF AND MAIN SPRING RELEASED PRIOR TO ENTERING THE TRAP HOUSE. NEVER ATTEMPT TO MAKE ANY ADJUSTMENTS WHEN THE THROW ARM IS IN THE COCKED POSITION.

The following are the instructions for re-timing the turret pinion assembly on the G-Series Pat-Trap® Machine:

1. Unload the targets from the machine's turret and lift the turret off of the king pin. (Note: It is easier to remove the turret if two people lift up on opposite sides of the turret, i.e., 180° apart)

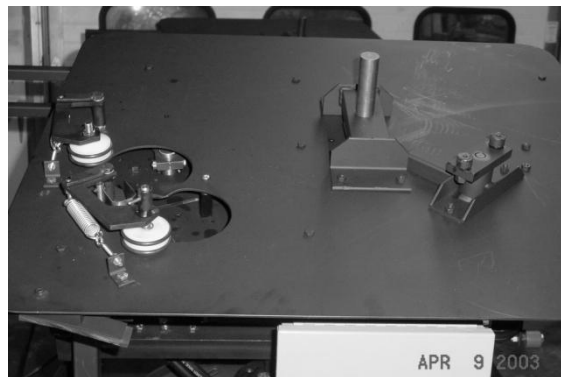

Picture 1.

2. Turn the pump on. Allow it to warm up for ten minutes or more if the temperature is cold. The Pump switch is the right-hand switch in Picture 2 below.



Picture 2.



3. Turn the machine on. When the throw arm comes forward to the throw arm brake and stops, it is in the cocked position. (See picture 3 below)

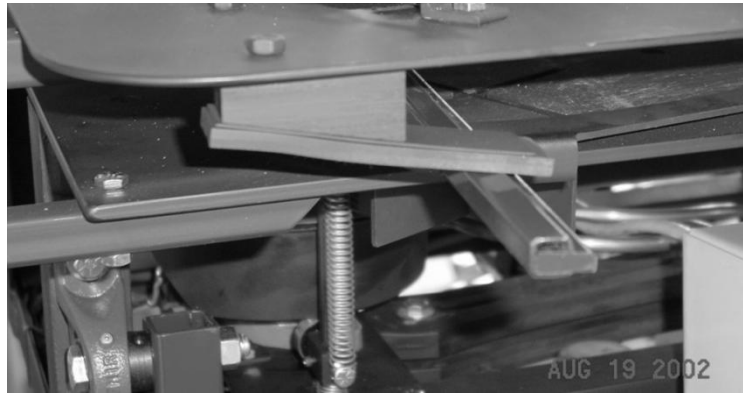

Picture 3.

4. Turn off the trap machine (Left Switch in Picture 2 above). Release the trap manually by standing clear of the throw arm and pushing the throw arm off the brake.
5. Compare the position of the pinion block on your trap machine with Diagram 1. The diagram represents the top view of the pinion block in relation to its base. The measurement given is taken from the corner "A" of the pinion block to the outside edge "B" of the pinion base (steel channel). The distance between points "A" and "B" is approximately 3/16" when correctly timed.

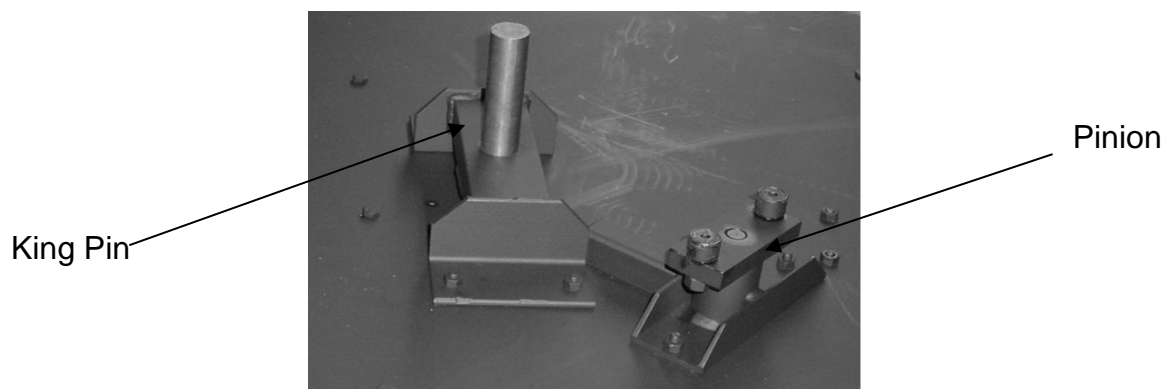

Picture 4.

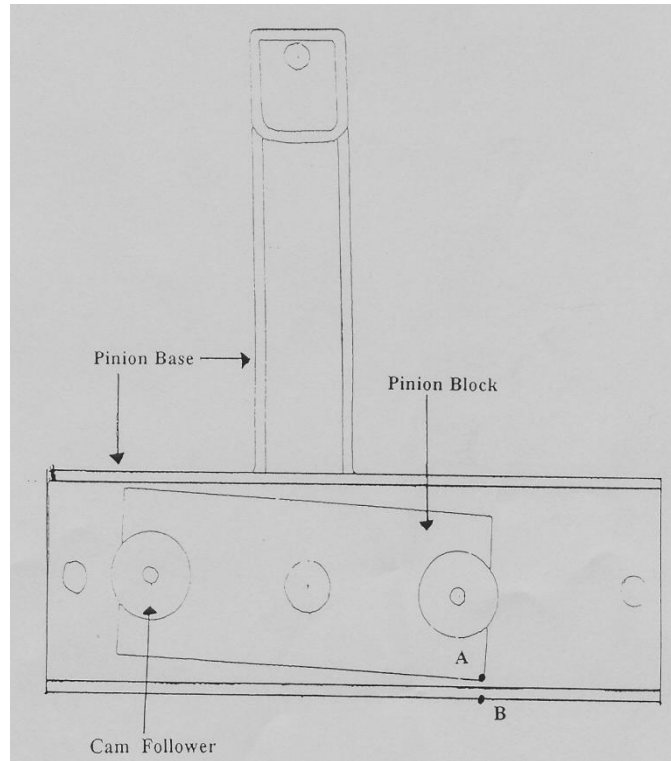

Diagram 1.

6. If the distance between points “A” and “B” is not close to the 3/16” spacing, then the timing can be corrected by disconnecting the drive chain to the pinion sprocket and rotating the pinion to the correct position and replacing the drive chain. See Picture 5.





Picture 5.

7. Note: The connecting link is located on the chain between the large sprocket and the small sprocket. If you can not see it, you will have to turn the trap machine on again and cycle it (repeat steps 3 and 4 above) until the connecting link comes around to the position required to remove it. Be sure to stay clear of the throw arm and that the machine is off and that the throw arm is released before working on the chain. Use a small screwdriver to remove the keeper bale for the connecting chain link. Once the chain is removed, position the pinion so that points "A" and "B" are at the 3/16" measurement, then reconnect the chain and the connecting link.



Picture 6.

8. Please call if you have any questions (603) 428-3396.



PROCEDURE TO FLUSH HYDRAULIC OIL

1. Please read completely before proceeding.
2. Remove the targets from the machine.
3. Turn the machine on, press the **RIGHT** oscillation button and oscillate all the way to the right until the cylinder bottoms-out.
4. For a Wobble machine, push the **UP** button until the cylinder bottoms out.
5. Leave the throw arm in the cocked position and turn the machine off.
6. Stand clear of the throw arm and disconnect the return-line hose (the bottom coupling).
7. A male coupling with three or four feet of hose now needs to be connected to the bottom coupling to direct the flow of oil into a pail.
8. The throw arm should still be in the cocked position. Turn the pump on and run until drained. Then, take the disconnected return-line hose and hold at full length above the pump and depress the ball valve to drain the oil from the hose. **NOTE:** You need to use the tip of your thumb or a screwdriver when depressing the ball so that the hose isn't blocked.
9. Leaving the throw arm in the cocked position, turn off the pump.
10. Fill the tank with new oil. **USE 5W-20.** Add oil as needed after each of the following steps.
11. The next steps require having the pull cord release switch in your hand. First, turn the on/off/release switch **ON**.
12. Depress the pull cord button.
13. Turn the pump switch **ON**. The throw arm will fire and the turret will index.
14. Turn **OFF** the pump switch **IMMEDIATELY** when the throw arm has re-cocked.
15. Press the **LEFT** oscillation button and hold in while turning the pump switch **ON**. As soon as the cylinder bottoms-out, turn the pump **OFF**.
16. For the Wobble machine, Press the **DOWN** button and hold in while turning the pump switch **ON**. As soon as the cylinder bottoms-out, turn the pump **OFF**.
17. Re-connect the return-line hose. (See instruction 4)
18. The machine is now full of oil. Fill the tank to within one inch of the top.
19. Turn the machine on and move the wobble cylinder to center and move the oscillation cylinder to center. Resume normal operation.



TROUBLE SHOOTING

NEVER STAND IN FRONT OF A TRAP MACHINE. THE TRAP MACHINE MUST BE TURNED OFF AND THE SPRING RELEASED BEFORE ENTERING THE TRAP HOUSE. NEVER ATTEMPT TO MAKE ANY ADJUSTMENT WHILE THE THROW ARM IS COCKED.

OSCILLATION PROBLEM for Standard Pat-Trap machine (Wobble machine)

Stand to right and rear of the machine near the Electrical Enclosure Box. Turn the machine on. Put the Auto/Manual switch into the manual position. If the left and right push buttons work then the Hydraulic Solenoid valve is good. If the buttons do not work, check the fuse, (Page 59 of the manual). If the fuse is blown this usually indicates that the Soft Shift Valve (P/N 9061) is bad.

AUTO MODE #11 & #12 (11A & 12A) SWITCHES

If the **#11 (11A) Switch** (N/O Left Angle Limit Reed Switch P/N 9223-G) is stuck “open” then the machine will travel all of the way right (down). This will cause the relief valve in the pump to engage and create a load noise.

Switch to Manual Mode and use the manual push button to bring the machine back to center and replace the switch

If the **#12 (12A) Switch** (N/O Left Angle Limit Reed Switch P/N 9222-G) is stuck “open” then the machine will travel all of the way to the left (down) This will cause the relief valve in the pump to engage and create a load noise.

Switch to Manual Mode and use the manual push button to bring the machine back to center and replace the switch.

If the **#11 (11A) Switch** (N/O Right Angle Limit Reed Switch P/N 9223-G) is stuck “closed” then the machine will travel all of the way to the left (all the way down) as usual. This will cause the relief valve in the pump to engage and create a loud noise.

Switch to Manual Mode and use the manual push button to bring the machine back to center and replace the switch.

If the **#12 (12A) Switch** (N/O Left Angle Limit Reed Switch P/N 9222-G) is stuck “closed” then the machine will travel all of the way to the right (all the way up). This will cause the relief valve in the pump to engage and create a load noise.



Switch to Manual Mode and use the manual push button to bring the machine back to center and replace the switch.

THE MACHINE DOES NOT OSCILLATE IN “MANUAL” MODE

Check the **Fuse**

If the Fuse is bad then the Oscillation Soft Shift Valve might be bad

Check the **Left** or **Right Push Button** for the fault

Check the **Auto/Manual Switch** for fault.

THE MACHINE DOES NOT OSCILLATE IN “AUTO” MODE

Check the **Fuse**

Replace the **Interrupter**

Replace the **#3 Switch**

Replace the **#2 Relay**

If the **Fuse** is bad then the **Oscillation Soft Shift Valve** might have a short.

Check the **Auto/Manual Switch** for a fault.

THE THROW ARM WILL NOT COCK

Check the **ON/OFF Release Switch** for fault.

Check the **#2 Switch**

Check the **Hydraulic Solenoid Valve**

THROW ARM WILL NOT RELEASE WITH PULL CORD, VOICE RELEASE, OR THE ON/OFF/RELEASE SWITCH IN THE POWER BOX

Check the plug ends at the pull cord or voice release connection

Replace the **#2 Switch**

Check the ON/OFF/RELEASE SWITCH with an OHM meter with the power unplugged.

THROW ARM DOES NOT STOP ON THE BRAKE (continually throws targets)

Disconnect the **Pull Cord** or **Voice Release System**

Check **Brake Assembly**

Check the **#2 Switch**: See “Cold Temperature Adjustment”



Check the **Hydraulic Solenoid Valve**

TARGETS BEGIN TO FALL SHORT OR THERE ARE AN UNUSUAL NUMBER OF TURNS ON THE CRANK HANDLE TO THROW A 50 YARD TARGET

Check for a broken **Uni-Band** (Main Spring)

Grease the **Main Shaft Bearing** with a low viscosity grease.

TARGETS ARE BEING THROWN MORE TO THE RIGHT

See **Target Brush** section

See **Throw Arm Maintenance** in **Maintenance** section

NEVER STAND IN FRONT OF A TRAP MACHINE. THE TRAP MACHINE MUST BE TURNED OFF AND THE SPRING RELEASED BEFORE ENTERING THE TRAP HOUSE. NEVER ATTEMPT TO MAKE ANY ADJUSTMENT WHILE THE THROW ARM IS COCKED.

BROKEN TARGETS

Check the **Target Brush**

Check the **O-rings**

Check the **Elevator Springs**

Check the **Roller Plate Spring** tension

Check the **Throw Plate** surface for corrosion: Sand with 80 grit sand paper if needed.

Check **Pinion Timing**

If throwing Doubles, check the **Doubles Finger**: there will be a problem if the **Double finger** is bent upwards.

Check the **Singles Finger** and **Doubles Finger** measurement. See Diagram 50



Index

Adjustments

Left/Right Angle Oscillation Limit Switches 9,23,56,60

Wobble Up/Down Limit Switches 9,17,62,58

Cold Weather 29

Target Speed/Distance 19,20,43

Singles/Doubles 12,13,15,17,18

Release Time (Stopping the Throw Arm on the brake) 30

Assembly

Throw Arm Brake 29,32,46

Throw Arm Cocking Pin 36

Uni-Band (Main Spring) 39,42,43,44,45

Brake

Assembly of Throw Arm Brake/Maintenance 29,32,46

Changing Uni-Bands on a Main Shaft Clutch System 43

Clutch, Main Shaft

Assembly/Installation of the Uni-Band (Main Spring) to the Main Shaft Clutch 39,42,43,44,45

Changing a Pair of Uni-Bands on a Main Shaft Clutch System
..... 43,45

Installation of Main Shaft Clutch 39,40,42

Cocking Pin Assembly (Throw Arm) 36

Cold Weather (Prevent Cycling of the Throw Arm) 29



Connection

Elevator Compression Spring 49

Elevator Extension Spring 48

Cycling Problem 29

Dimensions and Weight 5

Distance/Speed (Target) 19,20,21

Doubles

Setting Singles/Doubles Roller Plate System
..... 6, 13, 15, 16, 17, 20, 21, 27

Doubles Finger 16, 35, 37, 38

Doubles Finger, adjustment for doubles..... 16

Drying out a Pat-Trap..... Appendix VI

Elevation Cog 15, 22

Elevator Spring Replacement..... 48, 49

Field Angle Adjustment (Left/Right Limit Switches)
..... 56, 57, 60, 61, 64

Flush Hydraulic Fluid..... I

Fuse..... 59

Hydraulic Cylinder For Wobbles 9, 52, 58, 61, 62, 63, 64

Electrical Enclosure Box 14, 18, 57, 58, 59

Installation

Elevator Compression Spring 49



<i>Main Shaft Clutch</i>	39,440,42
<i>PAT-TRAP</i>	4
<i>Target Brush</i>	28
<i>Throw Arm</i>	34
<i>Throw Arm Brake</i>	33
<i>Uni-Band (Main Spring)</i>	45
<i>Uni-Band (Main Spring) to the Main Shaft Clutch</i>	45
<i>Doubles Finger</i>	37
<i>Interrupter Relay #3</i>	9,10,17,57,59
<i>Loading the PAT-TRAP</i>	4,11
<i>Limit Switch (Left/Right)</i>	10,24,56,57
<i>Main Shaft Clutch</i>	
<i>Assembly of Uni-Band to Main Shaft Clutch</i>	44
<i>Changing a Pair of Uni-Bands on a Main Shaft Clutch</i>	43
<i>Installation</i>	38,39,40,42
<i>Main Spring (uni-band), Disconnecting</i>	43
<i>Maintenance</i>	
<i>Flushing the Hydraulic Oil</i>	11
<i>Hydraulic Cylinder for the Wobble</i>	61
<i>Maintenance Schedule</i>	1
<i>Pump Motor</i>	61
<i>Target Brush</i>	28
<i>Throw Arm Brake</i>	32



Throw Arm Cocking Pin 36

Throw Arm Shaft Bearing 50

Grease fittings 50

Micro Switches #2 & #3 8,9,30,31

Mounting the Power Control Box 6

ON/OFF, How to turn on and off 11

Oil, How to Flush 11

Oil, How to turn on 6,11

Oscillation Cylinder, Replacement of 60

Oscillation Soft Shift Valve, Wiring Guide 53

On/Off/Release 7,8,10,11,13,14,15,16,29

Pat-Trap

Dimensions and Weight 5

How does it work 8

Installation 3

Loading 11

Singles 13

Doubles 15

Turn Off 11

Turn On 11

Wiring Guide V

Wobble 17



Pinion Assembly and Timing III

Positioning of Roller Plates 25

Power Control Box 6

Connecting..... 7

Mounting..... 2,3,6

Power Source Connection 7

Pull Cord (Switch #1) 7

Pump Motor..... 4

Flushing Hydraulic Fluid I

Pump Switch 6,10

Reed Switch

How it works8,9,10

Hydraulic Cylinder for Wobble 9,11

Wiring Guide#11 and #12 Switches 56

Removal/Replacement

Hydraulic Valve 55

Elevator Spring48,49

Field Angle/Limit Switch..... 57

Oscillation Cylinder 60

Wobble Cylinder 62

Positioning of the Roller Plate 25

Throw Arm 33



Turret 5

Relay #2 – L/R Oscillation 9,57,59

Relay #3 – Up/Down Wobble 58,59

Relay/Interrupter..... 9,10,17,57,59

Setting Single/Doubles 13,15,16,17,18,20,21,22

Shifting the Target Field..... 24

Singles..... 13

Single & Doubles Finger..... 37

Soft Shift Valve 51,52,53

Speed/Distance..... 19,20,21

Springs

Disconnecting the Uni-Band (Main Spring) 34

Elevator Compress Spring 48

Elevator Extension Spring.....25,48

Uni-band (Main Spring) 1,6,11,13,15,16,19,20,21,22

Straightaway Targets29,30

Switches

#2 & #3..... 8,9,10,30,31

#11 & #12 9,10,23,56

Switch ID..... 10

(Two) 2-Hole Targets/(Three)3-Hole Targets 23,24,56



Target Bush Maintenance 28

Targets

Angle Adjustment 9,23

Height Adjustment 18

Setting Speed and Distance 19,20

Target Field, shifting..... 29

Temperature/Release Time

Throw Arm

Brake Assembly29,32

Brake Installation 32

Cocking Pin Assembly 36

Installation 34

Removal of..... 33

Shaft Bearing..... 50

Stopping the Throw Arm on the Brake.....29,32

Throw Arm/Turret Valve Wiring Guide..... 54

Trouble Shooting VII

Turret, Removal/Replacement..... 6

Uni-Band See Main Spring

Valves

Soft Shift, Oscillation52,53

Throw Arm/Turret54,56



Wiring Guide

Hydraulic Cylinder for Wobble 58

Oscillation Soft Shift Valve..... 53

Pat-Trap & Wobble V

Switches #11 & #12..... 56

Throw Arm/Turret Valve 54

Wobble

Change over to..... 17, 18

Height Adjustment for Single/Doubles..... 17, 18

Hydraulic Cylinder58, 62

UP/DOWN Limit Switch.....58, 59



Diagram Index

<i>Top Down Suggested Plan View of Trap House</i>	2
<i>Side View (Cross Section) of Trap House</i>	3
<i>Hydraulic Pump System</i>	4
<i>Base Dimensions of Pat-Trap</i>	5
<i>Pat-Trap Serial # Location</i>	5
<i>Close up of Pat-Trap Power Control Box</i>	6
<i>Pat-Trap Machine Setup <u>Reference</u> Diagram</i>	7
<i>Throw Arm on Brake</i>	8
<i>#2 & #3 Switch Bracket in “Cocked” Position</i>	8
<i>#12 & #11 Limit Reed Switches on Oscillation Cylinder</i>	9
<i>#1 Switch Trap Release Switch</i>	9
<i>#11A & #12A Limit Reed Switches on Wobble Cylinder</i>	9
<i>Front and Rear Views of Interrupter</i>	10
<i>Single/Doubles Roller Plate in “Singles” position</i>	13
<i>Main Spring Crank Handle</i>	13
<i>Electrical Enclosure Box</i>	14
<i>Single/Doubles Roller Plate in “Doubles” position</i>	15
<i>Elevation Cog</i>	15
<i>Doubles Finger</i>	16
<i>Wobble Electrical Enclosure Box</i>	18
<i>Main Spring Crank Handle</i>	19
<i>10th Notch on Elevation Cog</i>	22



#12 Left Angle Limit Switch, #11 Right Angle Limit Switch, 2 Hole Spacer Bar 23

Roller Plate Assembly 25

Roller Plate Assembly Measurements..... 26 & 27

Target Brush Placement 28

Correct Position for Stopping the Throw Arm on the Throw Arm Brake 29

Side View of #2 & #3 Switch Bracket “on” the Activator Cam 30

Top View of #2 & #3 Switch Bracket “on” the Activator Cam 31

Throw Arm Brake Assembly 32

Removal/Installation of Throw Arm 33

Correct Height of Throw Arm #..... 34

Clearance of Throw Arm with target 35

Throw Arm Cocking Pin Assembly..... 36

Doubles Finger Installation 37

Doubles Finger measurement to the Singles Finger..... 38

Main Shaft Clutch Assembly 39

Rod End of Main Shaft Clutch Assembly..... 39

Position of Throw Arm when Installing Main Shaft Clutch Assembly 40

Securing the Throw Arm 40

Removing Main Spring Stand Off Collar..... 41

Main Shaft Clutch Assembly Connection to Throw Arm Crank 42

Main Spring (Uni-band) Clutch Assembly..... 45

Elevator Bearing Block On Cam 48

Elevator Extension and Compression Springs 48

Bottom of Elevator Guide..... 49



Throw Arm Drive Shaft ASsembly..... 50

Hydraulic Valve Identification.....51, 52

Soft Shift Valve Wiring Guide..... 53

Single Solenoid Valve Wiring Guide 54

Field Angle Limit Switch (#11 & #12) Wiring Guide..... 56 & 57

Wobble Up and Down Limit Switch(#11A & #12A) Wiring Guide 58 & 59

Removing Oscillation Cylinder Bar Bolts..... 60

Removing Shaft Rod-end Bolt from frame 61

Wobble Cylinder..... 62

Rod End Wobble cylinder mounted to trap frame..... 63

Mounting Bolt for Wobble Oscillation Cylinder..... 63

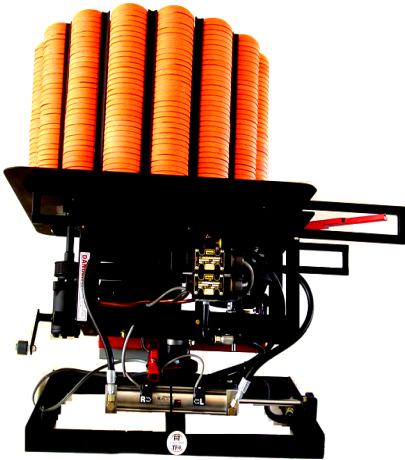

U.S. PATENTS(S): 5249563, 6176229

Pat-Trap®

AUTOMATIC SINGLE/DOUBLES

Manufactured by:

Pat-Trap, Inc
632 Western Ave
Henniker, NH. 03242

Telephone: 603-428-3396

Web Site: www.pattrap.com Email: pattrap@tds.net

Pat-Trap, Inc. warrants the Pat-Trap® Automatic Single/Doubles machine against defects in material or workmanship for a period of one year from date of original purchase; and agrees to repair **or**, at our option, replace any defective unit without charge.

IMPORTANT: This warranty does not cover transportation cost. Nor does it cover any damage resulting from accident, misuse or abuse, and any modifications or alterations including attaching the unit to other than the recommended receptacle or voltage.

NO RESPONSIBILITY IS ASSUMED FOR ANY SPECIAL, INCIDENTAL OR CONSEQUENTIAL DAMAGES.

Millions and Millions of Targets Served!